



1 and 1.5 Gallon Thermal Servers



1.5 gallon version shown
Style varies

See brewer user guide for brewing instructions

READ AND SAVE THESE INSTRUCTIONS

NOTICE TO INSTALLER: Please leave this booklet with the machine.

Symbols



This is the safety alert symbol. It is used to alert you to potential physical injury hazards. Obey all safety messages that follow this symbol to avoid possible injury or death.



DANGER - Indicates a hazardous situation which, if not avoided, will result in death or serious injury.



WARNING - Indicates a hazardous situation which, if not avoided, could result in death or serious injury.



CAUTION - Indicates a hazardous situation which, if not avoided, could result in minor or moderate injury.



NOTICE - Indicates a situation which, if not avoided, could result in property damage.



IMPORTANT - Provides information and tips for proper operation.



SANITATION REQUIREMENTS



WARNING - This product can expose you to chemicals including Acrylamide and Bisphenol A (BPA), which are known to the State of California to cause cancer and birth defects or other reproductive harm. For more information visit www.P65Warnings.ca.gov.

Important Safeguards/Conventions



WARNING:

- Keep hands, arms and other items away from hot surfaces.
- TO AVOID SCALDING, AVOID SPLASHING. Keep body parts clear of the brewer during brewing. Do not remove the brew basket while “Brewing” appears on the display.
- Clean the dispenser completely before using it for the first time as according to the CLEANING INSTRUCTIONS. Clean it regularly as instructed in the CLEANING INSTRUCTIONS. Do not use harsh powders or cleansers containing chlorine. Do not use a wire brush or pot scour to clean inside liner
- Thermal servers may be heavy when filled. Take care when transporting to avoid dropping or spilling.
- Use this unit only for its intended use, serving hot and/or cold beverages/water.
- This dispenser is not intended for use by persons (including children) with reduced physical, sensory or mental capabilities or lack of experience and knowledge, unless they have been given supervision or instruction concerning use of the dispenser by a person responsible for their safety.



Do not dispose of the FreshTrac® lids in an ordinary trash container. Contact you local municipality to determine acceptable procedures for disposal of electronic waste.

CE Requirements

- This dispenser must be used in locations where it can be overseen by trained personnel.
- For proper operation, this dispenser must be used where the temperature is between 5°C to 35°C.
- Dispenser shall not be tilted more than 10° for safe operation.
- This dispenser must not be cleaned by water jet.
- This dispenser can be used by persons aged from 18 years and above if they have been given supervision or instruction concerning use of the dispenser in a safe way and if they understand the hazards involved.
- Keep the dispenser and its cord out of reach of children aged less than 18 years.
- Dispensers can be used by persons 18 years and above with reduced physical, sensory or mental capabilities or lack of experience and knowledge if they have been given supervision or instruction concerning use of the dispenser in a safe way and understand the hazards involved.
- Children under the age of 18 years should be supervised to ensure they do not play with the dispenser.
- Dispenser must not be immersed for cleaning.
- Cleaning and user maintenance shall not be made by children unless they are older than 18 years and supervised.
- This dispenser is intended to be used in household and similar applications such as:
 - staff kitchen areas in shops, offices and other working environments;
 - by clients in hotels, motels and other residential type environments;
 - bed and breakfast type environments.
- This dispenser not intended to be used in applications such as:
 - farm houses
- Access to the service areas permitted by Authorized Service personnel only.
- The A-Weighted sound pressure level is below 70 dBA.

Cleaning the Thermal Dispenser (Daily)

The following cleaners are required to properly maintain the thermal dispenser:

- Mild solution of dish-washing detergent and warm water
- TABZ™ Coffee Equipment Cleaner Tablets*
- One-Pro Beverage Equipment Cleaner



WARNING: DO NOT immerse the dispenser or lid in water or any other liquid. Do not place the dispenser or lid in a dishwasher. Doing so will void the warranty. Do not use harsh powders or cleansers containing chlorine. Do not use a wire brush or scouring pad to clean inside the liner. **To avoid damage, DO NOT use a brush to clean the faucet or the inside of the faucet shank (outlet).**



IMPORTANT: Some dispensers have a stem on the bottom of the lid with a built-in sensor used for the FreshTrac® feature. Keep this stem free from coffee oil build-up for proper operation.

Cleaning the Container

- 1 Remove the lid. Rinse the dispenser and lid.
- 2 **Wash** - Prepare a mild solution of detergent and warm water. Wipe the exterior surfaces of the container and the lid with a sponge moistened with the detergent solution to remove spills and debris. Using the supplied brush, clean inside the fill tube on the lid. Fill the liner with the detergent solution. Use a sponge brush to scrub out the stainless steel liner.
- 3 **Rinse** - Rinse out the liner and lid with clean, warm water.
- 4 **Sanitize** - Reattach the lid, remove the cover and center the hole under the brew basket on the brewer. For 1.5 gal. (5.7 L) dispensers, drop one TABZ Z95 tablet into the brew basket. For 1.0 gal. (3.8 L) dispensers, drop two TABZ Z61 tablets into the brew basket. Slide the brew basket (with just the tablet[s] inside) into the brew rails on the brewer. Run a brew cycle and allow the liner to soak for 5 to 10 minutes after fluid stops flowing.
- 5 Open the faucet and drain out the sanitizer (to clean the faucet shank).
- 6 Fill the liner to the top with clean, warm water and drain through the faucet (to rinse the faucet shank).
- 7 Fill the liner to the top with water a second time and drain through the faucet. Rinse the lid thoroughly, pouring water through the brew-through hole and tube, during rinsing.

continued...

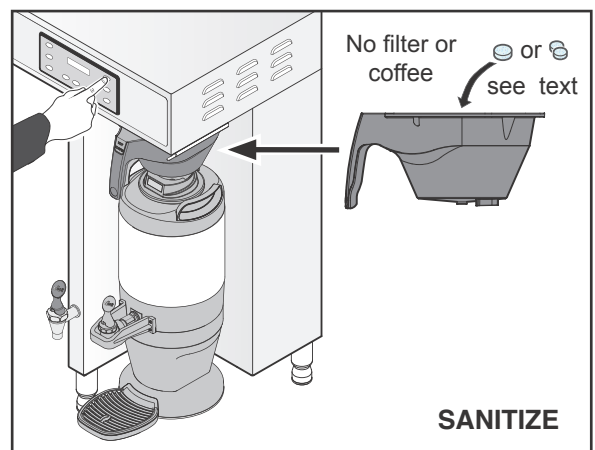
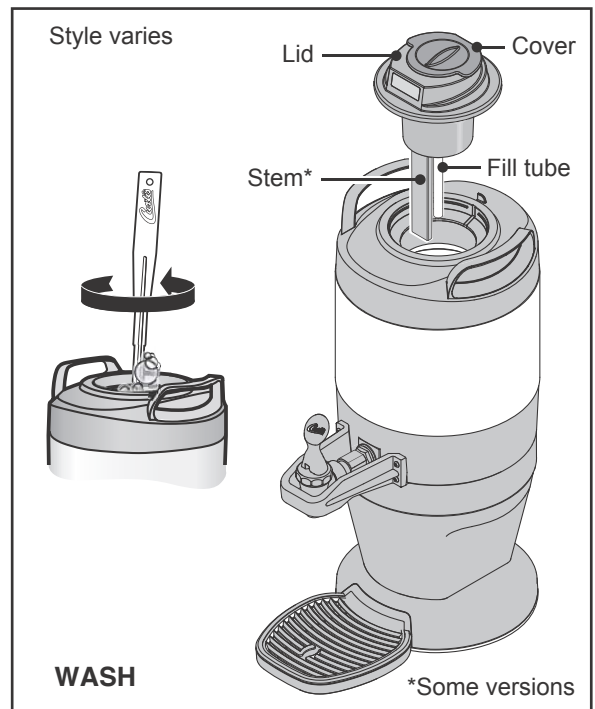

* For 1.5 gal./5.7 L dispensers use type Z95 (Curtis PN WC-79000)
 For 1.0 gal./3.8 L dispensers use type Z61 (Curtis PN WC-79003)

Cleaning the Thermal Dispenser (cont.)

8 Disassemble the faucet - Unscrew the handle/ bonnet assembly from the top of the faucet and remove it. Inspect the seat cup for wear. Replace the seat cup if it is damaged.

Disassemble the sight gauge (some versions). Unscrew the cap and guard to dis-assemble. Remove the glass tube. Inspect it for cracks or chips. If broken, replace the glass with a new one.

9 **Air Dry** - Turn the container and lid upside down and allow to air dry.

Cleaning the Faucet Parts and Site Gauge

10 **Wash** - Wash all faucet and gauge glass parts (if applicable) with the detergent solution. Clean the inside of the gauge glass with a gauge brush soaked with detergent solution.

11 **Rinse** - Thoroughly rinse all parts with clean, warm water.

12 **Sanitize** - After rinsing, place all faucet and gauge parts in a sink to be sanitized. Immerse them in One-Pro cleaner mixed at a ratio of 1 oz. (28 g.) per 5 gal. (19 L) of hot water (122°F/50°C min.). Allow the parts to soak for 15 minutes.

13 **Air Dry** - Remove the faucet parts from the sanitizer, rinse thoroughly and allow them to air dry.

14 Reassemble - When dry, reassemble the handle/ bonnet. Hand tighten the handle/bonnet onto the top of the faucet assembly, reinstall the site gauge (if applicable). If replacing a broken gauge glass, carefully remove any traces of glass from the silicone parts before inserting the new gauge glass tube. Reinstall the lid.

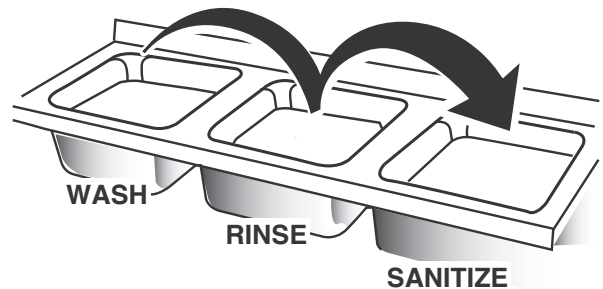
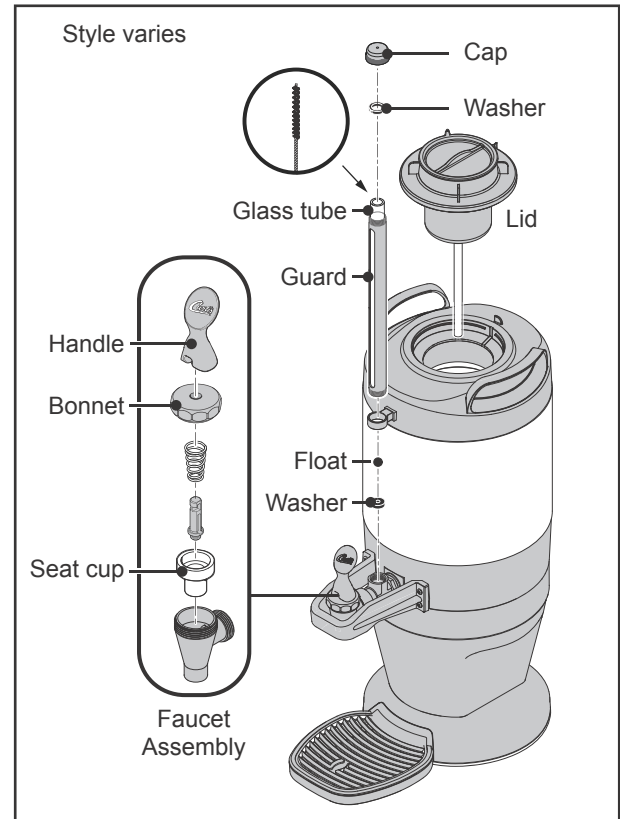

TXSG15 - Thermal Server

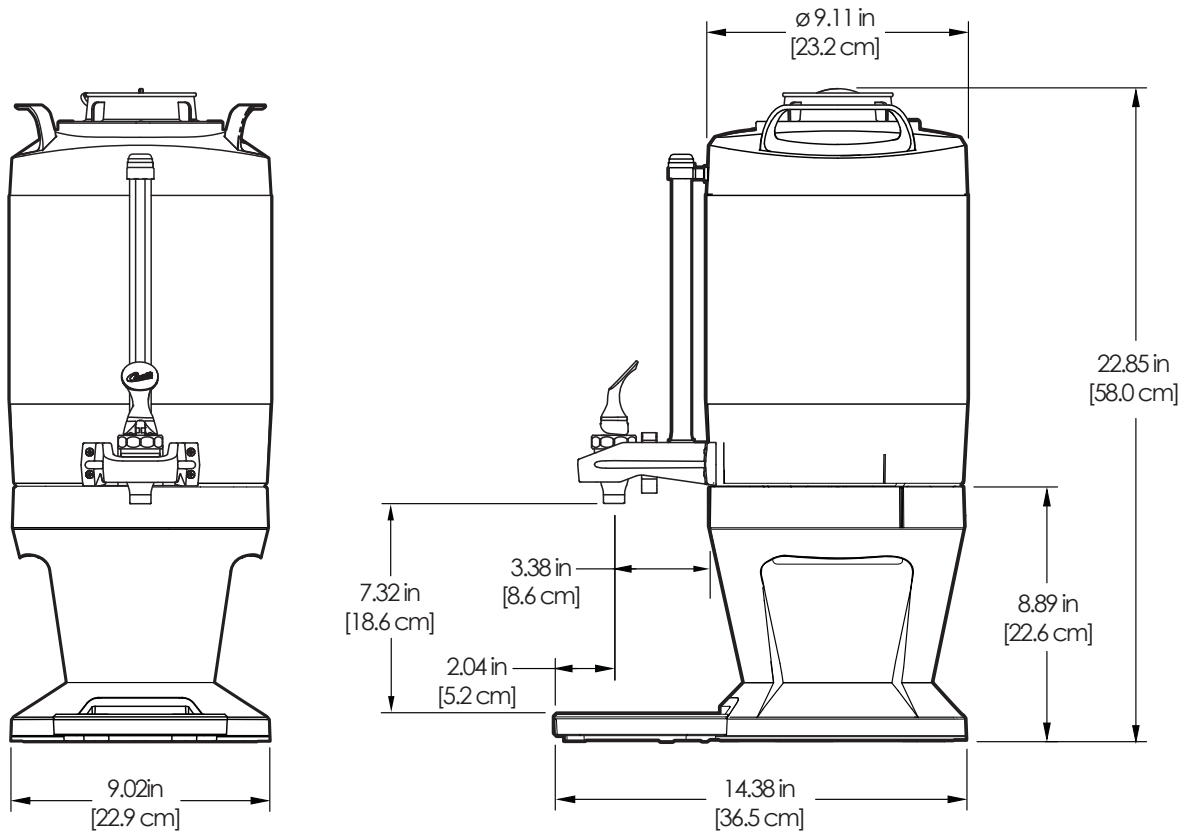

TXSG01 - Thermal Server

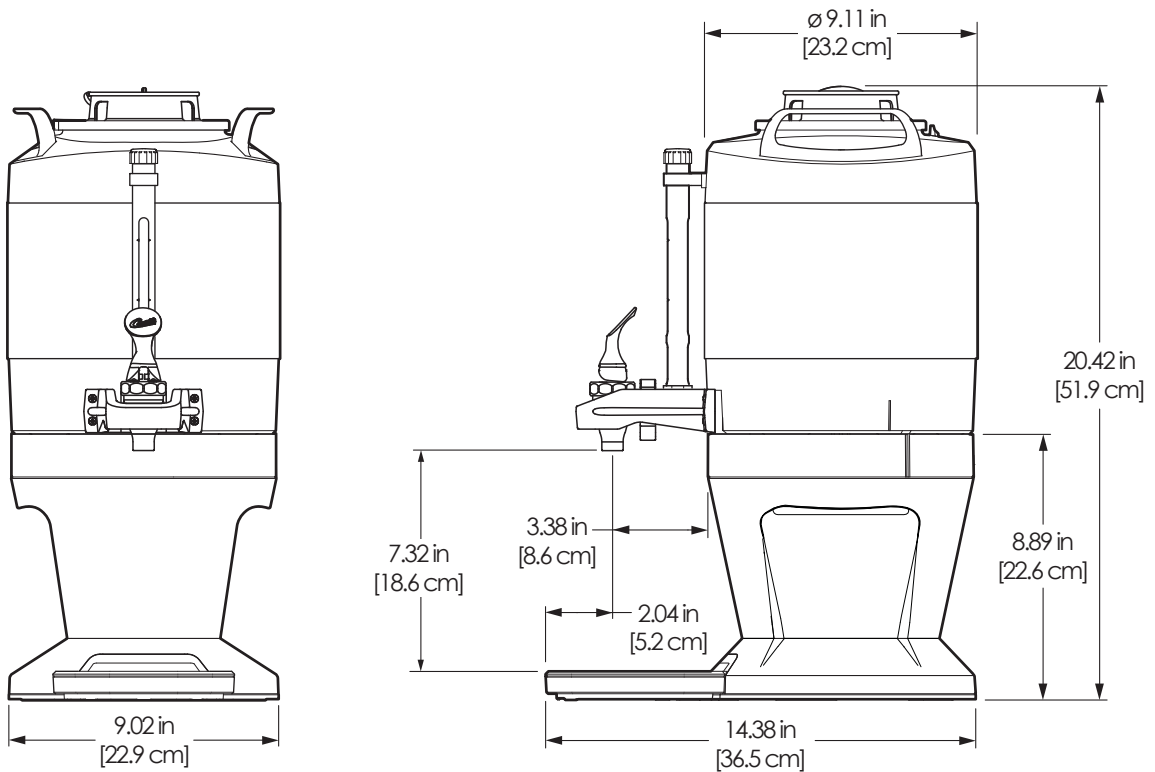

TXSG - Exploded View

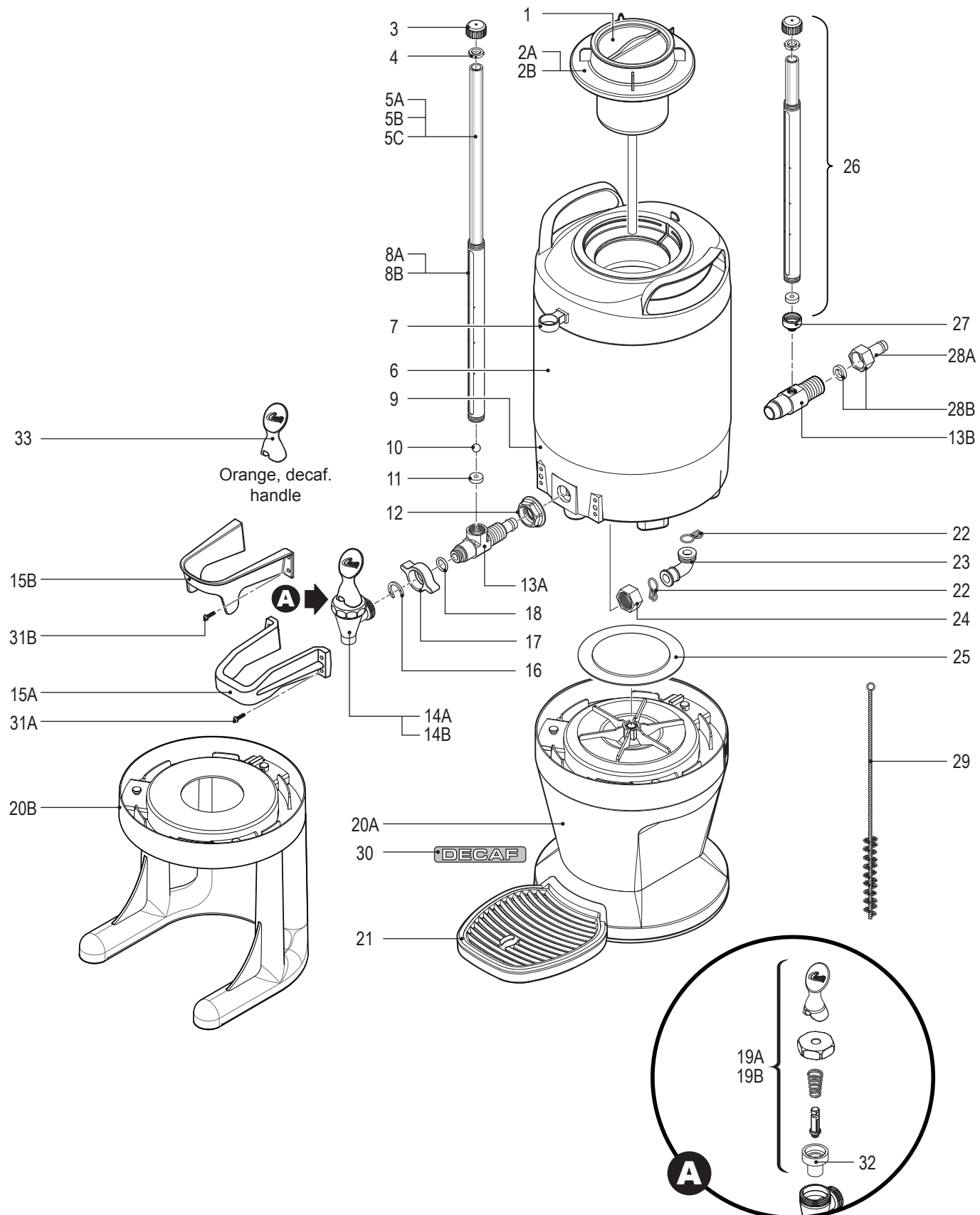

TXSG - Main Chassis - Parts List

All parts are common between the 1 gallon and 1.5 gallon servers, except where indicated by "TXSG15" and "TXSG01".

ITEM #	PART #	DESCRIPTION
1*	WC-56024-102	CAP, RUBBER FOR LARGE FUNNEL ASSY TXSG01, TXSG15
2A**	WC-56025-101	LID ASSEMBLY WITH LARGE FUNNEL TXSG15
2B**	WC-56024-101	LID ASSEMBLY WITH LARGE FUNNEL TXSG01
3	WC-1949	CAP, SHIELD WITH VENT, PLASTIC
4	WC-2005	WASHER, SHIELD CAP 1/8" GEM-3/TC'S W/SG
5A	WC-2027	GLASS, GAUGE 10" (TXSG15)
5B	WC-2025	GLASS, GAUGE 8" (TXSG01)
5C	WC-37396	KIT, GLASS GAUGE 10" 3PK FITS TXSG15 SERVER
6	WC-56028	TOP SERVER THREADED BLACK TXSG
7	WC-2063K	BRACKET, GAUGE GLASS RING & SC CREW FITS SHANGHAI SOLID SRVR
8A	WC-2012-101	SHIELD, GAUGE GLASS 10" BLACK ANODIZED (TXSG15)
8B	WC-2010-101	SHIELD, GAUGE GLASS 3/4"D.X 8" BLACK ANODIZE (TXSG01)
9	WC-56030	BOTTOM, PLASTIC BLK SERV TXSG
10	WC-32004	BALL, PLASTIC RESTRICTOR TXS SERVERS
11	WC-2006	WASHER, .188 ID X .188 THK BOTTOM GAUGE GLASS GEN USE
12	WC-1951	NUT, FLANGED, PLASTIC
13A	WC-1938-103K	KIT, SHANK, NUT & INSTRUCTIONS TXSG 1GAL. & 1.5GAL
13B	WC-1938	SHANK, PLASTIC CAP-T2 (OLDER UNITS)
14A	WC-1803	FAUCET, "SPB" SERIES, BLACK HANDLE/PLATIC 1-1/32-14 UNS CURT
14B	WC-1803D	FAUCET ASSY DECAF HANDLE PLASTIC 1-1/32-14 UNS CURTIS
15A	WC-66119K-TXSG	KIT, FAUCET GUARD TXSG (NEWER UNITS, INCLUDES SCREWS)
15B	WC-64079	GUARD, FAUCET TXSG CAST ZINC (OLDER UNITS)
16	WC-1906	"C" RING .917 X .760 X .090 TT-3 TC'S

ITEM #	PART #	DESCRIPTION
17	WC-1905	NUT, WING PLASTIC 1-1/32-14UNF (TC-2,3,5,10)
18	WC-4320	O'RING, 0.4871.D.x 0.693OD x0.103CS BUNA-N #112
19A	WC-3705	KIT, FAUCET HANDLE S SERIES NONLOCK
19B	WC-3705D	KIT, FAUCET S SERIES DECAF NON LOCK USE ON WC-1800D
20A	WC-56020	BASE ASSEMBLY SERVER 1 GAL & 1 1/2 GAL STRAIGHT SIDE
20B	WC-56013	BASE ASSEMBLY, SERVER TLXG15 TSS1/TSS2 (OPTIONAL)
21	WC-61689	KIT, DRIP TRAY STRAIGHT SIDE SERVER
22	WC-43091	CLAMP, WIRE HOSE TXSG01/TXSG15
23	WC-2456	ELBOW, SILICONE STRAIGHT SIDED SERVER TXSG01/TXSG15
24	WC-4281	NUT, 1/2"-14 NPSM PLASTIC
25	WC-58262	COVER, BOTTOM WHITE PLASTIC TXS TXSG01/TXSG15
26	WC-37395	KIT, GAUGE GLASS ASSY 10" BLK STRAIGHT SIDE SERVER 1.5 GAL
27	WC-2004-101	SHIELD, BASE GAUGE GLASS BLACK CHROME (OLDER UNITS)
28A	WC-29082	FITTING, 1/2"-14 NPSM STAINLESS STEEL WB5GT (OLDER UNITS)
28B	WC-29082K	KIT, FITTING W/ SILICONE WASHER FOR TXS SERVERS (OLDER UNITS)
29	WC-36076	BRUSH, GAUGE GLASS MILANO SERVER
30	WC-38281	LABEL, DECAF TLXG02
31A	WC-4872-25	SCREW, M4 X 25MM PHIL PAN HD BLACK-OXIDE 18-8 SS (NEWER UNITS)
31B	WC-4872	SCREW, METRIC PAN HD PHIL MACH BLK-OXIDE 18-8 SS, M4, 16mm LG (OLDER UNITS)
32	WC-1805	SEAT CUP, "S" FAUCET USE ON WC-1800/B/LB/D/DL/L/WC-1803
33	WC-32005ORG	HANDLE, FAUCET STYLIZED ORG CURTIS

* If server is equipped with a screw-on type cap, replace entire lid assembly (Item 2A or 2B).

** Compatible with older versions.

Wilbur Curtis Co., Inc. certifies that its products are free from defects in material and workmanship under normal use. The following limited warranties and conditions apply:

- 3 years, parts and labor, from original date of purchase on digital control boards
- 2 years, parts, from original date of purchase on all other electrical components, fittings and tubing
- 1 year, labor, from original date of purchase on all other electrical components, fittings and tubing

Additionally, Wilbur Curtis Co., Inc. warrants its grinding burrs for four (4) years from the date of purchase. Stainless steel components are warranted for two (2) years from the date of purchase against leaking or pitting. Replacement parts are warranted for ninety (90) days from the date of purchase or for the remainder of the limited warranty period of the equipment in which the component is installed.

All in-warranty service calls must have prior authorization. For authorization, call the Technical Support Department at 800-995-0417. Additional conditions may apply. Go to www.wilburcurtis.com to view the full product warranty information.

CONDITIONS & EXCEPTIONS

The warranty covers original equipment at time of purchase only. Wilbur Curtis Co., Inc., assumes no responsibility for substitute replacement parts installed on Curtis equipment that have not been purchased from Wilbur Curtis Co., Inc. Wilbur Curtis Co., Inc. will not accept any responsibility if the following conditions are not met. The warranty does not cover:

- **Adjustments and cleaning:** *The resetting of safety thermostats and circuit breakers, programming and temperature adjustments are the responsibility of the equipment owner. The owner is responsible for proper cleaning and regular maintenance of this equipment.*
- **Replacement of items subject to normal use and wear:** *This shall include, but is not limited to, spray heads, faucets, light bulbs, shear disks, "O" rings, gaskets, silicone tubing, silicone elbows, canister assemblies, whipper chambers and plates, mixing bowls, agitation assemblies and whipper propellers.*

The warranty is void under the following circumstances:

- **Improper operation of equipment:** *The equipment must be used for its designed and intended purpose and function.*
- **Improper installation of equipment:** *This equipment must be installed by a professional technician and must comply with all local electrical, mechanical and plumbing codes.*
- **Improper voltage:** *Equipment must be installed at the voltage stated on the serial plate supplied with this equipment.*
- **Improper water supply:** *This includes, but is not limited to, excessive or low water pressure and inadequate or fluctuating water flow rate.*
- **Damaged in transit:** *Equipment damaged in transit is the responsibility of the freight company and a claim should be made with the carrier.*
- **Abuse or neglect (including failure to periodically clean or remove lime accumulations):** *The manufacturer is not responsible for variation in equipment operation due to excessive lime or local water conditions. The equipment must be maintained according to the manufacturer's recommendations.*
- **Unauthorized repair or modification:** *This equipment must be serviced only by qualified service technicians, using factory specified parts to factory specifications.*
- **Modified/Missing Serial Tag:** *The serial number label (tag) must not be defaced or removed.*

Repairs and/or Replacements are subject to Curtis' decision that the workmanship or parts were faulty and the defects showed up under normal use. All labor shall be performed during regular working hours. Overtime charges are the responsibility of the owner. Charges incurred by delays, waiting time, or operating restrictions that hinder the service technician's ability to perform service is the responsibility of the owner of the equipment. This includes institutional and correctional facilities. Wilbur Curtis Co., Inc. will allow up to 100 miles, round trip, per in-warranty service call.

Return Merchandise Authorization (RMA): All claims under this warranty must be submitted to the Wilbur Curtis Technical Support Department prior to performing any repair work or return of this equipment to the factory. **All returned equipment must be properly re-packaged in the original carton and received by Curtis within 45 days following the issuance of a RMA.** No units will be accepted if they are damaged in transit due to improper packaging. **NO UNITS OR PARTS WILL BE ACCEPTED WITHOUT A RETURN MERCHANDISE AUTHORIZATION (RMA). THE RMA NUMBER MUST BE MARKED ON THE CARTON OR SHIPPING LABEL. All warranty claims must be submitted within 60 days of service. Invoices will not be processed or accepted without a RMA number. Any defective parts must be returned in order for warranty invoices to be processed and approved.** All in-warranty service calls must be performed by an authorized service agent. Call the Wilbur Curtis Technical Support Department to find an agent near you.