

ICB TWIN TF 1.0 Gal PE, 120/240V SST

Height: 25.1" Width: 22.6" Depth: 24.4"
(63.8cm) (57.4cm) (62.0cm)



- Intuitive 4.3" touchscreen with user interface provides an enhanced experience when operating and programming the brewers
- SmartWAVE sprayhead technology creates an industry best uniformity of extraction for exceptionally smooth tasting coffee
- Platinum Edition SmartWave technology delivers a timed air purge at the end of the brew cycle, removing residual water from the sprayhead, reducing lime build up and ultimately extending the life of the equipment
- The ICB Twin Infusion Series coffee brewer delivers twice the brew capacity, from a single platform
- Multiple recipes from one footprint --- with six brew buttons and three batch sizes
- Large 5.6 gallon (21.2L) tank provides back-to-back brewing capacity
- USB port for easy programming
- Digital readout displays in English, Spanish, or French ---for easier programming and control
- Energy-saver mode reduces tank temperature during idle periods
- Electronic funnel lock prevents removal of each brew funnel until drip- through is complete
- ICB Twin TF 54200.0100 is compatible with new TF 1.0-gallon Baseless ThermoFresh® Servers, all previous generations of TF 1.0-gallon Baseless TF Servers, and Airpots
- PROP 65 Warning Decal included in packaging with equipment

Server(s) sold separately

Agency: Servers not included unless otherwise noted



Specifications

Product #: 54200.0100
Water Access: Plumbed
Interface: Wireless
Finish: Stainless
Funnel: Smart Funnel
Faucet: Lower
Legs: 4" Satin Nickel Legs

Additional Features

Hot Water Button

Electrical & Capacity

Volts*	Amps	Watts	Cord Attached	Plug Type	8oz cups/hr 236ml cups/hr	Input H ₂ O Temp.	Phase	# Wires plus Ground	Hertz
120/240	25	6000	Yes/	-	280	60°F (15.5°C)	1	3	60

*When a BUNN is machine rated 120/208-240V, 120/208V or 120/240V, the higher voltage is the supply voltage needed to power the machine. The 120V is there to supply power to some components rated 120V in the machine, but it is not the supply voltage and would not power the machine if the machine is marked with the before mentioned ratings.

Plumbing Requirements

PSI	kPa	Fitting Supplied	Water Flow Required (GPM)
20-90	138-621	3/8" Male Flare Fitting	1.00

CAD Drawings

2D	Revit	KLC
●	●	●

WARNING: This product can expose you to chemicals including Bisphenol A (BPA), which is known to the State of California to cause birth defects or other reproductive harm. For more information go to www.P65Warnings.ca.gov



BUNN® reserves the right to change specifications and product design without notice. Such revisions do not entitle the buyer to corresponding changes, improvements, additions or replacements for previously purchased equipment. For most current specifications and other info visit bunn.com.

Last Updated:
07/09/2021

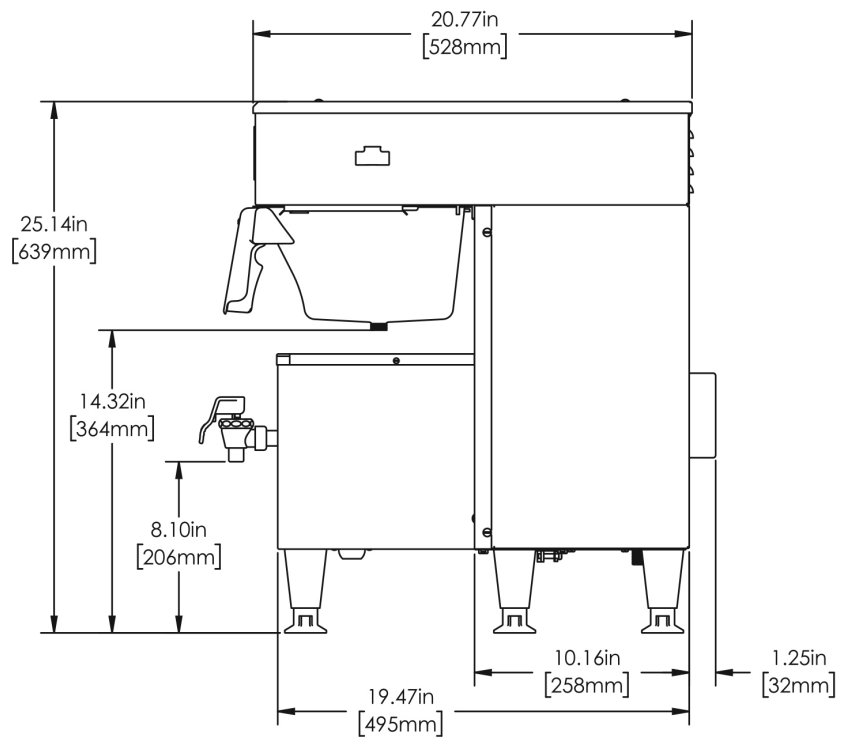
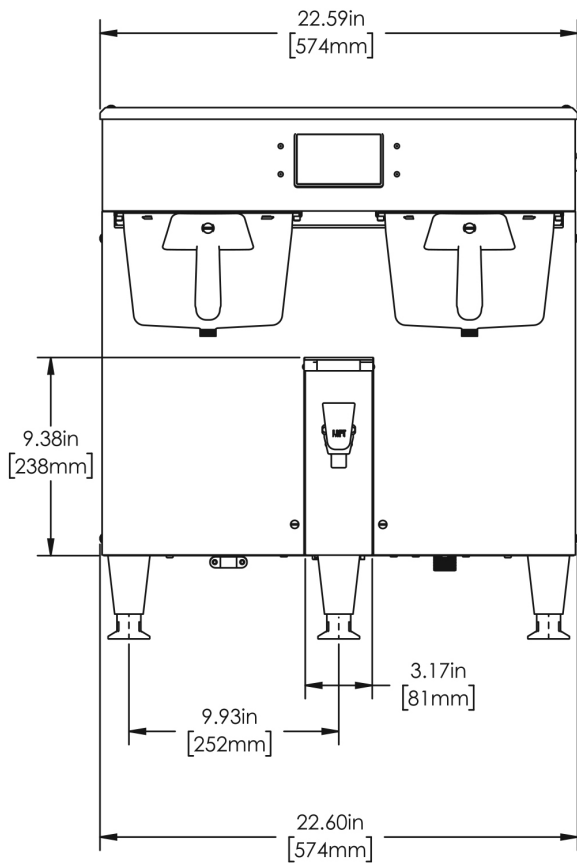
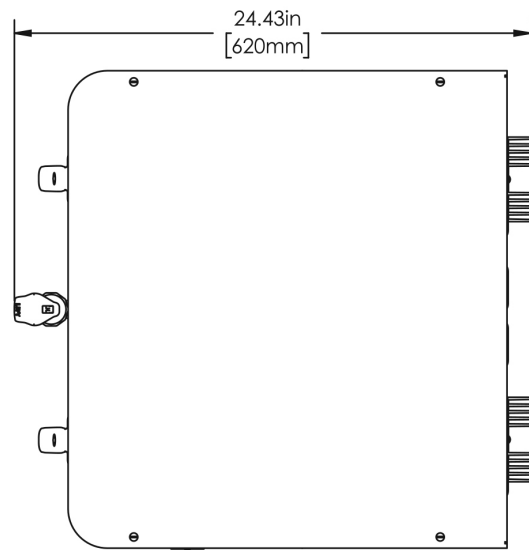

	Unit			Shipping				
	Height	Width	Depth	Height	Width	Depth	Weight	Volume
English	25.1 in.	22.6 in.	24.4 in.	30.8 in.	25.8 in.	26.7 in.	87.600 lbs	12.259 ft³
Metric	63.8 cm	57.4 cm	62.0 cm	78.1 cm	65.6 cm	67.8 cm	39.735 kgs	0.347 m³



BUNN® reserves the right to change specifications and product design without notice. Such revisions do not entitle the buyer to corresponding changes, improvements, additions or replacements for previously purchased equipment. For most current specifications and other info visit bunn.com.

Last Updated:
07/09/2021

Related Products & Accessories: ICB TWIN TF 1.0 Gal PE, 120/240V SST(54200.0100)



FILTERS, GOURMET 500
500/1 50/CL

Product #: 20138.1000



STAND ASSY, TF
SERVER GEN3

Product #: 39795.0200



STAND ASSY KIT, TF
SERVER

Product #: 54473.1000



BUNN® reserves the right to change specifications and product design without notice. Such revisions do not entitle the buyer to corresponding changes, improvements, additions or replacements for previously purchased equipment. For most current specifications and other info visit bunn.com.

Last Updated:
07/09/2021

Serving & Holding Options: ICB TWIN TF 1.0 Gal PE, 120/240V SST(54200.0100)



TF SERVER, 1G DSG
GEN3

Product #:42700.0200



TF SERVER, 1G DSG
GEN3 NOBASE

Product #:42700.0250



TF SERVER, 1.5G DSG
GEN3

Product #:42750.0200



TF SERVER, 1.5G DSG
GEN3 NOBASE

Product #:42750.0250



TF SERVER, 1G MECH
GEN3

Product #:44000.0200



TF SERVER, 1G MECH
GEN3 NOBASE

Product #:44000.0250



TF SERVER, 1.5G MECH
GEN3

Product #:44050.0200



TF SERVER, 1.5G MECH
NOBASE GEN3

Product #:44050.0250