



SMART WAVE[®] Series

Smart Wave Series

Smart Wave Silver Series

Combo Coffee/Tea Brewer



INSTALLATION & OPERATING GUIDE

BUNN-O-MATIC CORPORATION

POST OFFICE BOX 3227

SPRINGFIELD, ILLINOIS 62708-3227

PHONE: (217) 529-6601 FAX: (217) 529-6644

To ensure you have the latest revision of the Operating Manual, or to view the Illustrated Parts Catalog, Programming, or Service Manual, please visit the Bunn-O-Matic website, at www.bunn.com. This is absolutely FREE and the quickest way to obtain the latest catalog and manual updates. For Technical Service, contact BUNN at 1-800-286-6070

BUNN-O-MATIC COMMERCIAL PRODUCT WARRANTY

Bunn-O-Matic Corp. ("BUNN") warrants equipment manufactured by it as follows:

- 1) Airpots, thermal carafes, decanters, GPR servers, iced tea/coffee dispensers, MCR/MCP/MCA single cup brewers, thermal servers and ThermoFresh® servers (mechanical and digital) 1 year parts and 1 year labor.
- 2) All other equipment - 2 years parts and 1 year labor plus added warranties as specified below:
 - a) Electronic circuit and/or control boards - parts and labor for 3 years.
 - b) Compressors on refrigeration equipment - 5 years parts and 1 year labor.
 - c) Grinding burrs on coffee grinding equipment to grind coffee to meet original factory screen sieve analysis - parts and labor for 4 years or 40,000 pounds of coffee, whichever comes first.

These warranty periods run from the date of installation BUNN warrants that the equipment manufactured by it will be commercially free of defects in material and workmanship existing at the time of manufacture and appearing within the applicable warranty period. This warranty does not apply to any equipment, component or part that was not manufactured by BUNN or that, in BUNN's judgment, has been affected by misuse, neglect, alteration, improper installation or operation, improper maintenance or repair, non periodic cleaning and descaling, equipment failures related to poor water quality, damage or casualty. In addition, the warranty does not apply to replacement of items subject to normal use including but not limited to user replaceable parts such as seals and gaskets. This warranty is conditioned on the Buyer 1) giving BUNN prompt notice of

any claim to be made under this warranty by telephone at (217) 529-6601 or by writing to Post Office Box 3227, Springfield, Illinois 62708-3227; 2) if requested by BUNN, shipping the defective equipment prepaid to an authorized BUNN service location; and 3) receiving prior authorization from BUNN that the defective equipment is under warranty. THE FOREGOING WARRANTY IS EXCLUSIVE AND IS IN LIEU OF ANY OTHER WARRANTY, WRITTEN OR ORAL, EXPRESS OR IMPLIED, INCLUDING, BUT NOT LIMITED TO, ANY IMPLIED WARRANTY OF EITHER MERCHANTABILITY OR FITNESS FOR A PARTICULAR PURPOSE. The agents, dealers or employees of BUNN are not authorized to make modifications to this warranty or to make additional warranties that are binding on BUNN. Accordingly, statements by such individuals, whether oral or written, do not constitute warranties and should not be relied upon.

If BUNN determines in its sole discretion that the equipment does not conform to the warranty, BUNN, at its exclusive option while the equipment is under warranty, shall either 1) provide at no charge replacement parts and/or labor (during the applicable parts and labor warranty periods specified above) to repair the defective components, provided that this repair is done by a BUNN Authorized Service Representative; or 2) shall replace the equipment or refund the purchase price for the equipment.

THE BUYER'S REMEDY AGAINST BUNN FOR THE BREACH OF ANY OBLIGATION ARISING OUT OF THE SALE OF THIS EQUIPMENT, WHETHER DERIVED FROM WARRANTY OR OTHERWISE, SHALL BE LIMITED, AT BUNN'S SOLE OPTION AS SPECIFIED HEREIN, TO REPAIR, REPLACEMENT OR REFUND.

In no event shall BUNN be liable for any other damage or loss, including, but not limited to, lost profits, lost sales, loss of use of equipment, claims of Buyer's customers, cost of capital, cost of down time, cost of substitute equipment, facilities or services, or any other special, incidental or consequential damages.

392, A Partner You Can Count On, Air Infusion, AutoPOD, AXIOM, BrewLOGIC, BrewMETER, Brew Better Not Bitter, BrewWISE, BrewWIZARD, BUNN Espresso, BUNN Family Gourmet, BUNN Gourmet, BUNN Pour-O-Matic, BUNN, BUNN with the stylized red line, BUNNlink, Bunn-O-Matic, Bunn-O-Matic, BUNNserve, BUNNSERVE with the stylized wrench design, Cool Froth, DBC, Dr. Brew stylized Dr. design, Dual, Easy Pour, EasyClear, EasyGard, FlavorGard, Gourmet Ice, Gourmet Juice, High Intensity, iMIX, Infusion Series, Intellisteam, My Café, Phase Brew, PowerLogic, Quality Beverage Equipment Worldwide, RespectEarth, RespectEarth with the stylized leaf and coffee cherry design, Safety-Fresh, savemycoffee.com, Scale-Pro, Silver Series, Single, Smart Funnel, Smart Hopper, SmartWAVE, Soft Heat, SplashGard, The Mark of Quality in Beverage Equipment Worldwide, ThermoFresh, Titan, trifecta, TRIFECTA (stylized logo), Velocity Brew, Air Brew, Beverage Bar Creator, Beverage Profit Calculator, Brew better, not bitter., Build-A-Drink, BUNNsource, Coffee At Its Best, Cyclonic Heating System, Daypart, Digital Brewer Control, Element, Milk Texturing Fusion, Nothing Brews Like a BUNN, Picture Prompted Cleaning, Pouring Profits, Signature Series, Sure Tamp, Tea At Its Best, The Horizontal Red Line, Ultra are either trademarks or registered trademarks of Bunn-O-Matic Corporation. The commercial trifecta® brewer housing configuration is a trademark of Bunn-O-Matic Corporation.

CONTENTS

Warranty	2
Introduction	3
User Notices	3
Electrical Requirements	4
Plumbing Requirements	5
Initial Setup	6
Brewing	7
Operating Controls/ Programming	8
Deliming	12
Cleaning	13
Cover Removal	14
Draining Tank	15
Switch Settings	16
Troubleshooting	17
Schematic Wiring Diagrams	18

INTRODUCTION

This equipment is factory set to brew approximately 64 ounces of coffee into an awaiting dispenser. It is only for indoor use on a sturdy counter or shelf.

USER NOTICES



#00986.0000



#00824.0002



#42878.0000



#00658.0000

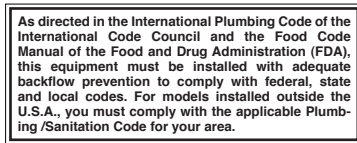

#00656.0001

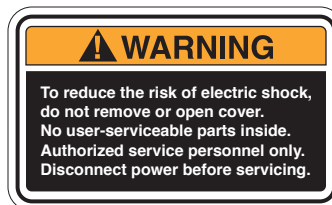

#37881.0000



#03409.0002



#03408.0002



#37881.0002

CE Requirements

- This appliance must be installed in locations where it can be overseen by trained personnel.
- For proper operation, this appliance must be installed where the temperature is between 5°C to 35°C.
- Appliance shall not be tilted more than 10° for safe operation.
- An electrician must provide electrical service as specified in conformance with all local and national codes.
- This appliance must not be cleaned by water jet.
- This appliance is not intended for use by persons (including children) with reduced physical, sensory or mental capabilities, or lack of experience and knowledge, unless they have been given instructions concerning use of this appliance by a person responsible for its safety.
- Children should be supervised to ensure they do not play with the appliance.
- If the power cord is ever damaged, it must be replaced by the manufacturer or authorized service personnel with a special cord available from the manufacturer or its authorized service personnel in order to avoid a hazard.
- Machine must not be immersed for cleaning.
- If this appliance can be used by children aged from 18 years and above if they have been given supervision or instruction concerning use of the appliance in a safe way and if they understand the hazards involved.
- Cleaning and user maintenance shall not be made by children unless they are older than 18 and supervised.
- Keep the appliance and its cord out of reach of children aged less than 8 years.
- The instructions of coffee-makers shall state that cleaning and user maintenance shall not be made by children without supervision.
- Shall state that the coffee-maker shall not be placed in a cabinet when in use.
- Must state intended application and non-application:
 - This appliance is intended to be used in household and similar applications such as
 - bed and breakfast type environments
 - by clients in hotels, motels and other residential type environments.
 - Farm houses
 - Staff kitchen areas in shops
 - Office and othe working environments

ELECTRICAL REQUIREMENTS

CAUTION - The brewer must be disconnected from the power source until specified in Initial Set-Up.

Refer to Data Plate on the Brewer, and local/national electrical codes to determine circuit requirements.



100V & 120V
Models

120 & 220-240 volt ac models

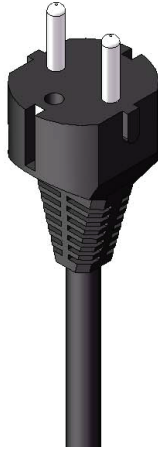

220-240 VOLT CE Model

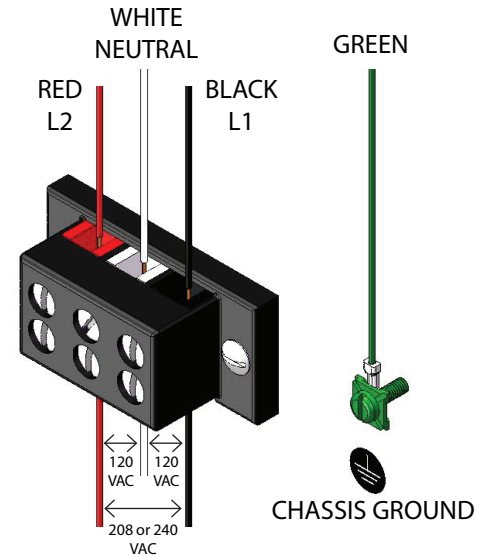

120/240 VOLT Model

120/208 & 120/240 volt ac models

Note: This electrical service consists of 2 current carrying conductors (L1 and Neutral) and a separate conductor for chassis ground.

Note: This electrical service consists of 3 current carrying conductors (Neutral, L1 and L2) and a separate conductor for chassis ground.

Electrical Hook-Up

CAUTION – Improper electrical installation will damage electronic components.

1. An electrician must provide electrical service as specified.
2. Using a voltmeter, check the voltage and color coding of each conductor at the electrical source.
3. If plumbing is to be hooked up later be sure the brewer is disconnected from the power source. If plumbing has been hooked up, the brewer is ready for Initial Set-Up.

PLUMBING REQUIREMENTS

These brewers must be connected to a cold water system with operating pressure between 20 and 90 psi (0.138 and 0.620 MPa) from a ½" or larger supply line. A shut-off valve should be installed in the line before the brewer. Install a regulator in the line when pressure is greater than 90 psi (0.620 MPa) to reduce it to 50 psi (0.345 MPa). The water inlet fitting is ¼" flare. Bunn-O-Matic does not recommend the use of a reverse-osmosis or deionized water supply to this equipment.

NOTE - Bunn-O-Matic recommends ¼" copper tubing for installations of less than 25 feet and ⅜" for more than 25 feet from the ½" water supply line. A tight coil of tubing in the water line will facilitate moving the brewer to clean the countertop. Bunn-O-Matic does not recommend the use of a saddle valve to install the brewer. The size and shape of the hole made in the supply line by this type of device may restrict water flow.

NOTE - If a backflow preventer is required by code, a shock arrestor should be installed between backflow preventer and brewer. Installing the shock arrestor as close to brewer as possible will provide best results.

As directed in the International Plumbing Code of the International Code Council and the Food Code Manual of the Food and Drug Administration (FDA), this equipment must be installed with adequate backflow prevention to comply with federal, state and local codes. For models installed outside the U.S.A., you must comply with the applicable Plumbing /Sanitation Code for your area.

Plumbing Hook-Up

1. Remove the shipping cap from the fitting on the rear of the brewer.
2. Securely attach adaptor elbow assembly to the fitting at the rear of the brewer.
3. Flush the water line and securely attach it to the adaptor elbow.
4. Turn on the water supply.

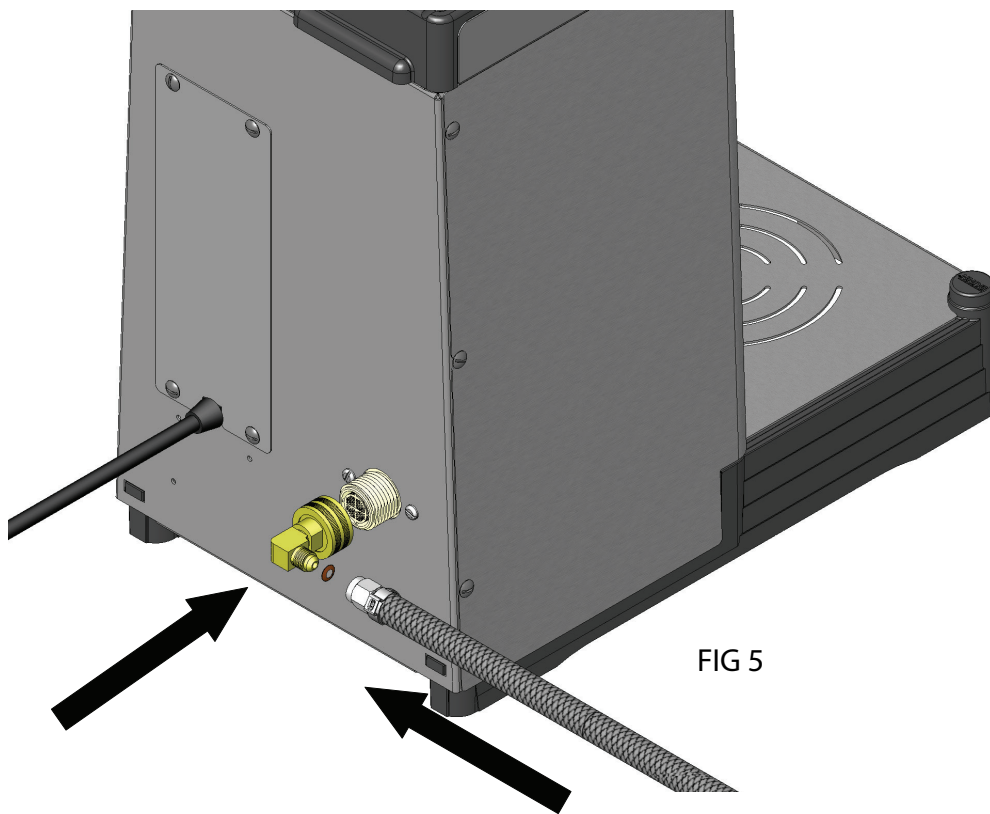

INITIAL SET UP

CAUTION - The brewer must be disconnected from the power source throughout the initial set-up, except when specified in the instructions.

1. Insert an empty funnel into the funnel rails. (FIG 6A)
2. Place an empty server (customer supplied) under the funnel. For taller servers, lift up on the front of the booster plate, and slide it back into the trunk housing.

NOTE: If more height is need, the legs may be extended to a maximum of 1¾". (FIG 6B)

3. Connect the brewer to the power source.
4. Press and release the "ENABLE BREW ON/OFF" switch. (Indicator/Display must be lit!). Water will flow into the tank and stop when the tank is filled to its capacity.
5. Wait approximately twenty minutes for the water in the tank to heat to the proper temperature. Display will show "READY" (green light on Silver Series) when tank is at operating temperature. Some water will drip from the funnel during this time; this is due to expansion and is normal part of setup.
6. Water volumes and flow settings have been preset at the factory. Refer to Adjustments Section of this manual to set brew volumes should the volume need to be increased or decreased.
7. The brewer is now ready for use in accordance with the instructions for Coffee Brewing.



FIG 6A

1¾" Max.



FIG 6B

COFFEE BREWING

1. Begin each brew cycle with a clean empty brew funnel.
2. Insert a BUNN filter into the funnel. (FIG 7A)
3. Pour (or grind) fresh coffee into the filter and level the bed of grounds by gently shaking.
4. Slide the funnel into the funnel rails until it stops (FIG 7B).
5. Place an empty server (customer supplied) under the funnel.
6. Verify that the "ENABLE BREW ON/OFF" switch is on.
7. Momentarily press and release the desired "BREW" switch. The display will read "BREWING" (flashing red light on Silver Series). NOTE: On combo Tea/Coffee models, press the BREW A switch.
8. After the coffee finishes dripping from the funnel tip, carefully remove the brew funnel and discard the grounds and filter. Rinse funnel.

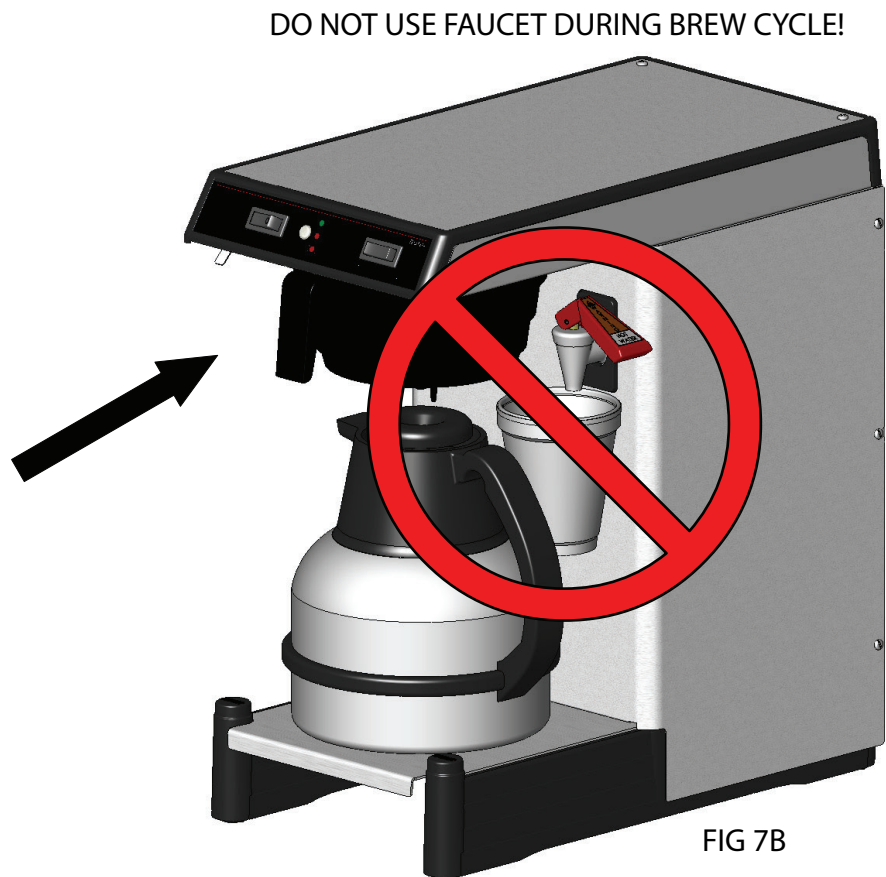
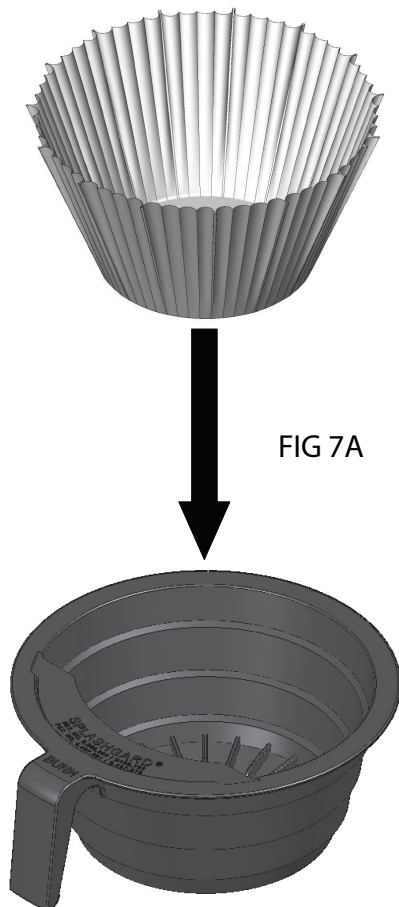

TEA BREWING

1. Begin each brew cycle with a clean empty tea funnel.
2. Insert a BUNN filter into the tea funnel (FIG 8A).
3. Pour fresh tea into the filter and level by gently shaking.
4. Slide the funnel into the funnel rails until it stops.
5. Place an empty server (customer supplied) under the funnel (FIG 8B).
6. Verify that the "ENABLE BREW ON/OFF" switch is on.
7. Momentarily press and release the "BREW B" switch. The display will read "BREWING".
8. After the tea finishes dripping from the funnel tip, carefully remove the brew funnel and discard the tea and filter. Rinse funnel.

DO NOT REMOVE SERVER UNTIL DILUTION CYCLE IS COMPLETED!

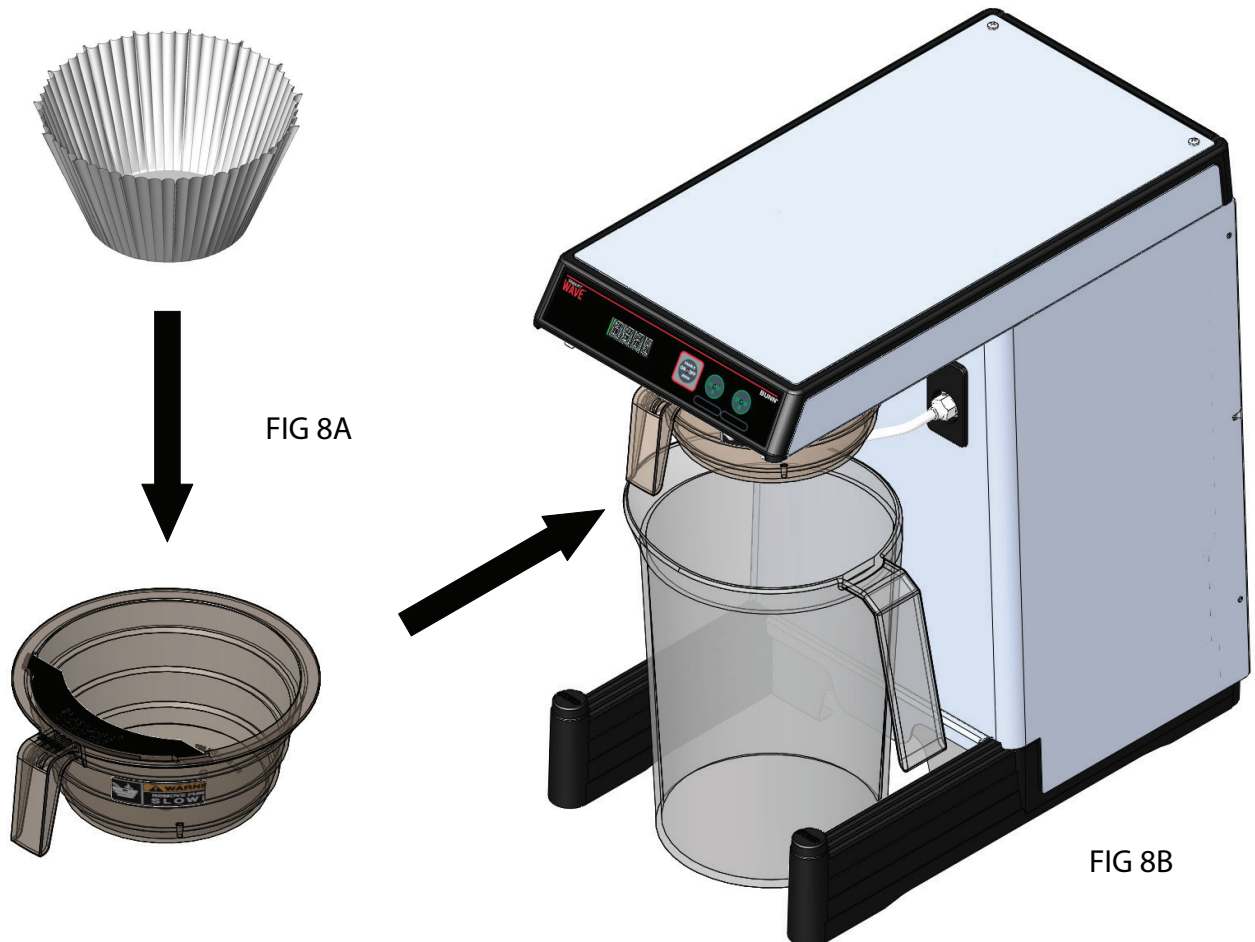

OPERATING CONTROLS - SILVER SERIES

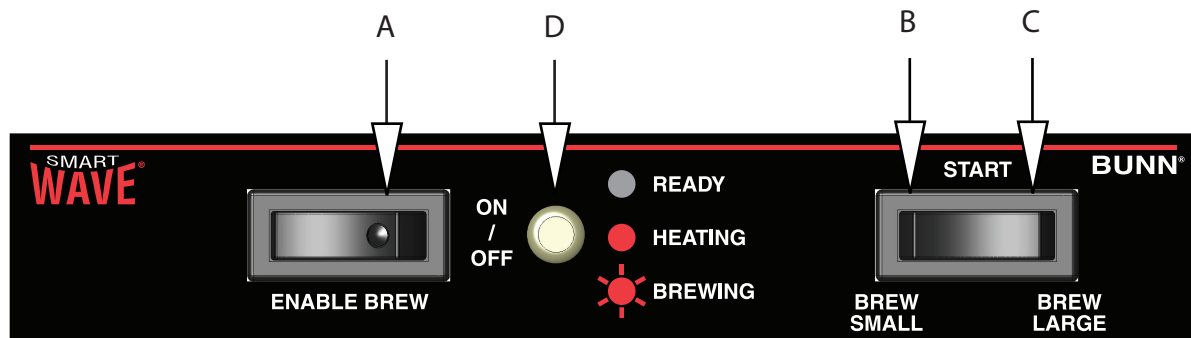

FIG 9

Smart Wave Silver Series

(A) ENABLE BREW ON/OFF SWITCH

Pressing the "ENABLE BREW ON/OFF" switch (indicator on) enables the brew circuit, and energizes the tank refill circuit. Pressing the switch again (indicator off) stops tank refilling and brewing. Stopping a brew cycle after it has been started will not stop the flow of water into the server until the funnel is empty.

NOTE 1: – Stopping a brew cycle by pressing the "ENABLE BREW ON/OFF" switch to the "OFF" position, will disable the tank refill circuit. If the level is low enough, tank heating may be disabled as well. Simply pressing the "ENABLE BREW ON/OFF" switch to the "ON" position will allow the tank to replenish. Allow a few minutes for the tank to heat back up to it's ready temperature.

NOTE 2: – Hot water will be available at the faucet in a limited amount when the "ENABLE BREW ON/OFF" switch is in the "OFF" position because the tank will not refill. Refer to NOTE 1 regarding low level.

(B) SMALL BREW SWITCH

Momentarily pressing and releasing the switch starts the selected "SMALL" brew cycle when the "ENABLE BREW ON/OFF" indicator is on. (Factory set for approx. 64 ounces)

(C) LARGE BREW SWITCH

Momentarily pressing and releasing the switch starts the selected "LARGE" brew cycle when the "ENABLE BREW ON/OFF" indicator is on. (Factory set for approx. 64 ounces)

(D) STATUS INDICATOR

Steady green - ready to brew.
Steady red - tank is heating up.
Flashing red - brew cycle in process.

PROGRAMMING - SILVER SERIES

BREW VOLUME SET-UP:

NOTE: Set small and large batches separately. Maximum water on time is 5 minutes.

Use the following steps when the setting is unknown.

1. Place an empty funnel in the funnel rails and an empty server beneath the funnel.
2. Press the "ENABLE BREW ON/OFF" switch ("ON").
3. Press and hold the small brew start switch until the LED indicator alternately flashes red/green (approximately 15 seconds). Release the switch.
4. Allow the cycle to continue until the desired amount of water is dispensed and then press the "ENABLE BREW ON/OFF" to turn "OFF" the brewer.

The brewer is now set to dispense this amount of water for each subsequent small brew cycle.

To increase the amount of water for each brew cycle place an empty funnel in the funnel rails and an empty server beneath the funnel. Press the "ENABLE BREW ON/OFF" switch (ON). Press and hold the small "BREW" switch until you hear the solenoid click on-and-off three times (approximately 10 seconds), then release the small "BREW" switch. Momentarily press and release the small "BREW" switch once for each ounce (approximate) of water to be added to the prior setting and allow the brew cycle to finish.

To decrease the amount of water for each brew cycle place an empty funnel in the funnel rails and an empty server beneath the funnel. Press the "ON/OFF" switch (ON). Momentarily press and release the small "BREW" switch once for each ounce (approximate) of water to be removed from the existing setting. Press and hold the small "BREW" switch until you hear the solenoid click on-and-off three times (approximately 10 seconds), then release the small "BREW" switch and allow the cycle to finish.

NOTE: Repeat the steps above to set the large batch by using the large brew switch as desired.

OPTIONAL PULSE BREW SET-UP:

NOTE: Set small and large batches separately. Brewer has 4 preset pulse brew routines to choose from.

Factory default is 1. With 4 being the maximum time.

With the machine off, press the small or large switch for 10 seconds. Red LED will flash to indicate current setting (1 – 4). Press same switch the number of times (1 – 4) for the desired setting. If the switch is pressed more than 4 times, the setting will remain at 4. After 5 seconds the red Led will resume flashing the selected number. When no switches are pressed for 30 seconds, the mode will exit. Or the mode may be exited by pressing the "ENABLE BREW ON/OFF" switch. Repeat above procedure with the other brew switch.

Restore Factory Defaults:

Press the "ENABLE BREW ON/OFF" switch while applying AC power. Continue pressing the "ENABLE BREW ON/OFF" switch for 10 seconds. During that 10 seconds, the red LED will be on steady. After 10 seconds the green LED will begin flashing rapidly for 5 seconds. During that 5 seconds, release and again momentarily press the "ENABLE BREW ON/OFF" switch again to restore default settings. The Led will alternate rapidly Red and Green for a few seconds indicating the restore has been accomplished.

Note: The Restore process cannot be done when Dip Switch # 1 is On (Program Lockout)

OPERATING CONTROLS - SMART WAVE WITH DISPLAY

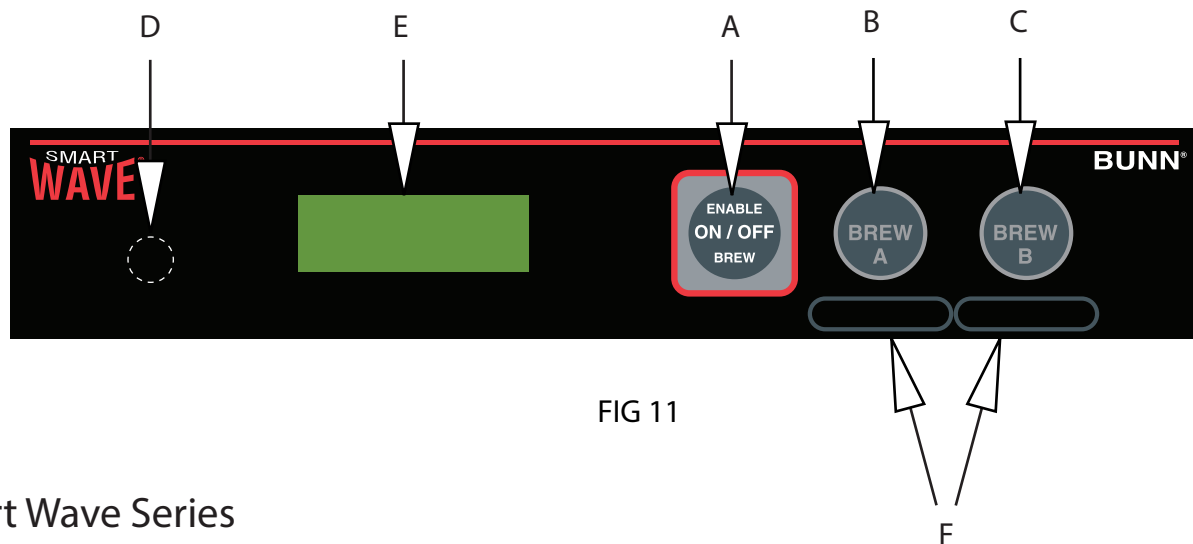

FIG 11

Smart Wave Series

(A) ENABLE BREW ON/OFF SWITCH

Pressing the "ENABLE BREW ON/OFF" switch (indicator/display on) enables the brew circuit, and the tank refill circuit. Pressing the switch again (indicator/display off) stops tank refilling and brewing. Stopping a brew cycle after it has been started will not stop the flow of water into the server until the funnel is empty.

NOTE 1: – Stopping a brew cycle by pressing the "ENABLE BREW ON/OFF" switch to the "OFF" position, will disable the tank refill circuit. If the level is low enough, tank heating may be disabled as well. Simply pressing the "ENABLE BREW ON/OFF" switch to the "ON" position will allow the tank to replenish. Allow a few minutes for the tank to heat back up to its ready temperature.

NOTE 2: – Hot water will be available at the faucet in a limited amount when the "ENABLE BREW ON/OFF" switch is in the "OFF" position because the tank will not refill. Refer to NOTE 1 regarding low level.

(B) BREW A SWITCH (-)

Momentarily pressing and releasing the switch starts the selected "A" brew cycle when the "ENABLE BREW ON/OFF" indicator is on. (Factory set for approx. 64 ounces) (Coffee brewing on combo models)

(C) BREW B SWITCH (+)

Momentarily pressing and releasing the switch starts the selected "B" brew cycle when the "ENABLE BREW ON/OFF" indicator is on. (Factory set for approx. 64 ounces) (Tea brewing on combo models)

(D) HIDDEN PROGRAM SWITCH (Enter)

(E) STATUS DISPLAY

Indicates tank ready, brew cycle, and drip out cycle.

(F) BATCH SIZE/FLAVOR LABELS

Included

PROGRAMMING - SMART WAVE WITH DISPLAY

BREW VOLUME SET-UP:

NOTE: Maximum water on time is 5 minutes.

1. Press the "HIDDEN" switch until display reads A1. This represents the adjust mode "Brew Time" for the "A" brew switch. The display will then change to (minutes-seconds). Press "BREW A" to decrease time (-) or "BREW B" to increase time (+).
2. Press and release "HIDDEN" switch until display reads A2. This represents the adjust mode "Brew Meter" (Pulse Brew) for the "A" brew switch. The display will then change to (1-14). Brewer has 14 preset pulse brew routines to choose from. Factory default is 1. With 14 being the maximum time. Press "BREW A" to decrease (-) or "BREW B" to increase (+).
3. Press and release "HIDDEN" switch until display reads A3. This represents the adjust mode "Drip Out Time" for the "A" brew switch. The display will then change to (minutes-seconds). Press "BREW A" to decrease time (-) or "BREW B" to increase time (+).
4. Repeat steps 1 -3 for setting the "B" brew switch.

Adjustment	Default	Min.	Max.	Increments
A1 = Brew switch "A" Brew time	2:05	0:26	5:00	1 second
A2 = Brew switch "A" Brew meter	1	1	14	1
A3 = Brew switch "A" Drip out time	1:00	0:05	5:00	5 seconds
B1 = Brew switch "B" Brew time	2:05	0:26	5:00	1 second
B2 = Brew switch "B" Brew meter	1	1	14	1
B3 = Brew switch "B" Drip out time	1:00	0:05	5:00	5 seconds

ADVANCED SET-UP:

Press the "HIDDEN" switch until display reads P1. This represents the advanced adjust modes .

Adjustment	Default	Min.	Max.	Increments
P1 = Temperature set	200°F	185°F	205°F	1 Degree
P2 = Ready Temperature	195°F	180°F	198°F	1 Degree
P3 = Brew Count (Display Only)	0	0	9999	1 Brew Cycle
P4 = °F or °C	°F	N/A	N/A	N/A

TECHNICIAN SET-UP:

Press the "HIDDEN" switch until display reads U1. This represents the Technician adjust modes .

Adjustment	Default	Min.	Max.	Increments
U1 = Display Water Level Threshold	< 10	0	255	1
U2 = Adjust Water Level Threshold	85	30	220	1
U3 - U7 FACTORY ADJUSTMENTS		DO NOT ADJUST		
U8 = Calibrate Temperature Sensor	200°F	190°F	210°F	1°

Restore Factory Defaults:

Press the "ENABLE BREW ON/OFF" switch while applying AC power. Continue pressing the "ENABLE BREW ON/OFF" switch for 10 seconds. During that 10 seconds the middle bars on the display will be on. After 10 Seconds the the 3 upper, middle and lower bars on the display will be lit for 5 seconds. During that 5 seconds, release and again press the "ENABLE BREW ON/OFF" switch to restore default settings – the display will show "DONE".

Note: The Restore process cannot be done when Dip Switch # 1 is On (Program Lockout).

PROGRAMMING - SMART WAVE COMBO

BREW VOLUME SET-UP:

NOTE: Maximum water on time is 5 minutes.

1. Press the "HIDDEN" switch until display reads C1. This represents the adjust mode "Brew Time" for the "A" brew switch. The display will then change to (minutes-seconds). Press "BREW A" to decrease time (-) or "BREW B" to increase time (+).
2. Press and release "HIDDEN" switch until display reads C2. This represents the adjust mode "Brew Meter" (Pulse Brew) for the "A" brew switch. The display will then change to (1-14). Brewer has 14 preset pulse brew routines to choose from. Factory default is 1. With 14 being the maximum time. Press "BREW A" to decrease (-) or "BREW B" to increase (+).
3. Press and release "HIDDEN" switch until display reads C3. This represents the adjust mode "Drip Out Time" for the "A" brew switch. The display will then change to (minutes-seconds). Press "BREW A" to decrease time (-) or "BREW B" to increase time (+).
4. Press and release "HIDDEN" switch until display reads T1. This represents the adjust mode "Brew Time" for the "A" brew switch. The display will then change to (minutes-seconds). Press "BREW A" to decrease time (-) or "BREW B" to increase time (+).
5. Press and release "HIDDEN" switch until display reads T2. This represents the adjust mode "Brew Meter" (Pulse Brew) for the "B" brew switch. The display will then change to (1-14). Brewer has 14 preset pulse brew routines to choose from. Factory default is 1. With 14 being the maximum time. Press "BREW A" to decrease (-) or "BREW B" to increase (+).
6. Press and release "HIDDEN" switch until display reads T3. This represents the adjust mode "Drip Out Time" for the "B" brew switch. The display will then change to (minutes-seconds). Press "BREW A" to decrease time (-) or "BREW B" to increase time (+).
7. Press and release "HIDDEN" switch until display reads T4. This represents the adjust mode "Dilution Time" for the "B" brew switch. The display will then change to (minutes-seconds). Press "BREW A" to decrease time (-) or "BREW B" to increase time (+).
8. Press and release "HIDDEN" switch until display reads T5. This represents the adjust mode "Dilution Delay Time" for the "B" brew switch. The display will then change to (minutes-seconds). Press "BREW A" to decrease time (-) or "BREW B" to increase time (+). To have a quick dilution, set this time to zero.

NOTE: Advanced programming screens are same as standard Smart Wave.

	Adjustment	Default	Min.	Max.	Increments
C1	= Brew switch "A" Brew time	2:35	0:26	5:00	1 second
C2	= Brew switch "A" Brew meter	1	1	14	1
C3	= Brew switch "A" Drip out time	0:30	0:05	5:00	5 seconds
T1	= Brew switch "B" Brew time	1:15	0:26	5:00	1 second
T2	= Brew switch "B" Brew meter	1	1	14	1
T3	= Brew switch "B" Drip out time	0:30	0:05	5:00	5 seconds
T4	= Brew switch "B" Dilution out time	1:20	0:05	5:00	5 seconds
T5	= Brew switch "B" Dilution Delay	3:30	0:00	5:00	5 seconds

DELIMING

Bunn-O-Matic recommends deliming your coffee brewer periodically. The actual frequency of deliming depends on the mineral content of the water you use. NOTE: In hard water areas, this may need to be done daily. It will help prevent liming problems in the brewer and takes less than a minute.

Follow these simple steps:

1. Unplug the brewer and let it cool down before proceeding.
2. Remove the brew funnel.
3. Remove the sprayhead by turning it to the left with your fingertips and set it aside.
4. With the sprayhead removed, insert the deliming spring (provided) all the way into the sprayhead tube. When inserted properly, no more than two inches of spring should be visible. Saw back and forth five or six times. Remove the spring.
5. Check the holes in the sprayhead. If plugged by lime, they may be cleared using a toothpick. Rinse the sprayhead with water before reinstalling it.
6. Reinstall the sprayhead by turning it to the right.
7. Plug in the brewer and allow the water to reheat before using.

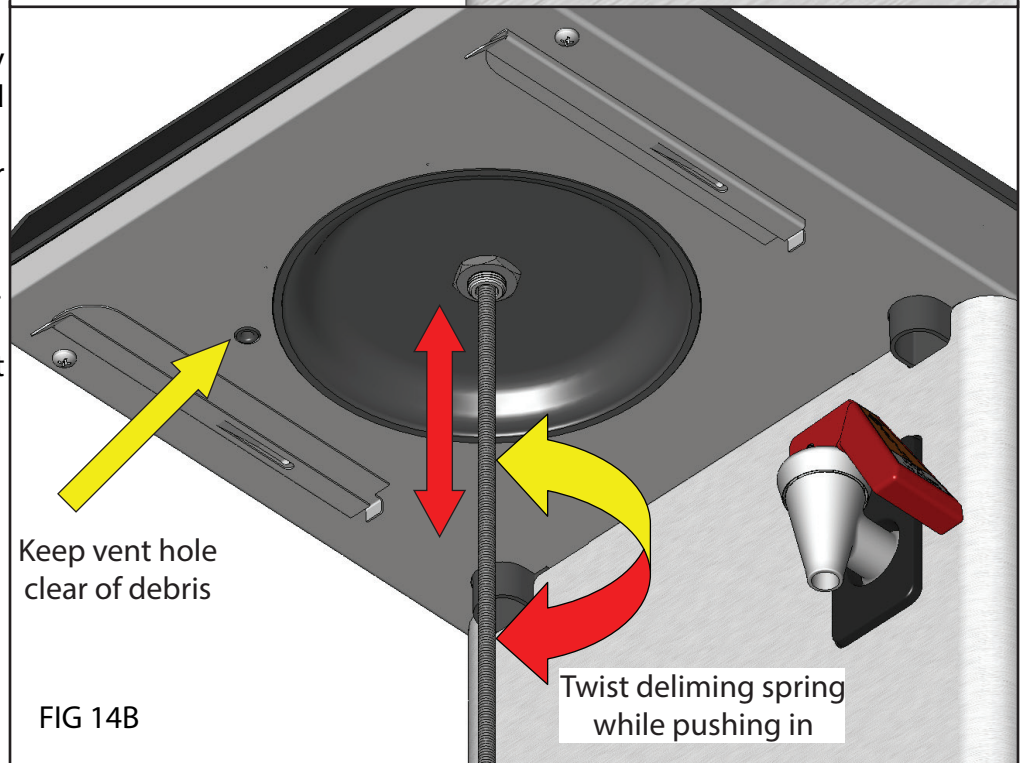
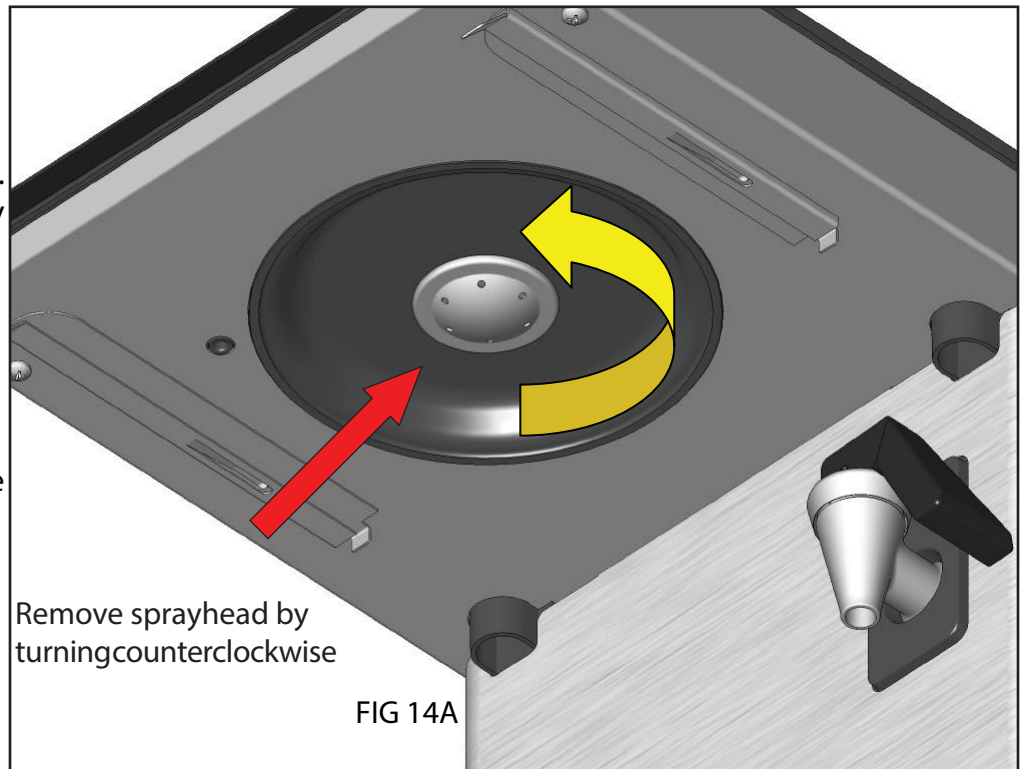

CLEANING

The use of a damp cloth rinsed in any mild, non-abrasive, liquid detergent is recommended for cleaning all surfaces on Bunn-O-Matic equipment.

CLEANING OPTIONAL LARGE SPRAYHEAD

1. Remove the brew funnel.
2. Remove the sprayhead by turning it counterclockwise with your fingertips.
3. Disassemble sprayhead by removing rubber gasket.
4. Check the holes in the sprayhead. If plugged by lime, they may be cleared using a toothpick. Rinse the sprayhead with water.
5. Reassemble the sprayhead according to FIG 15A. NOTE: Verify the indents are aligned. (ARROWS)
6. Reinstall the sprayhead by turning it clockwise. Hand tighten only!

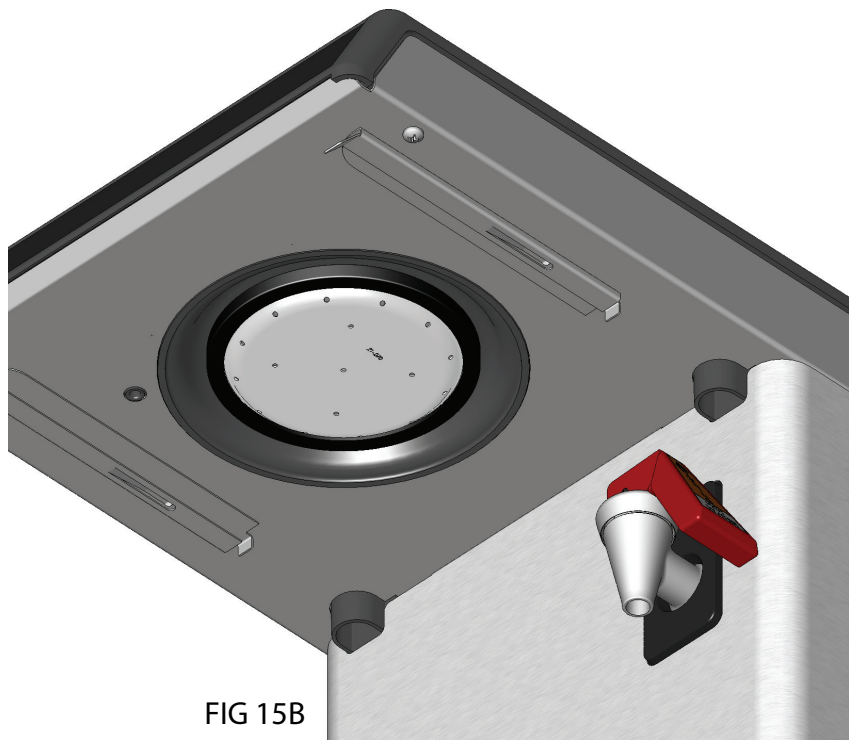

COFFEE/TEA
COMBO ONLY

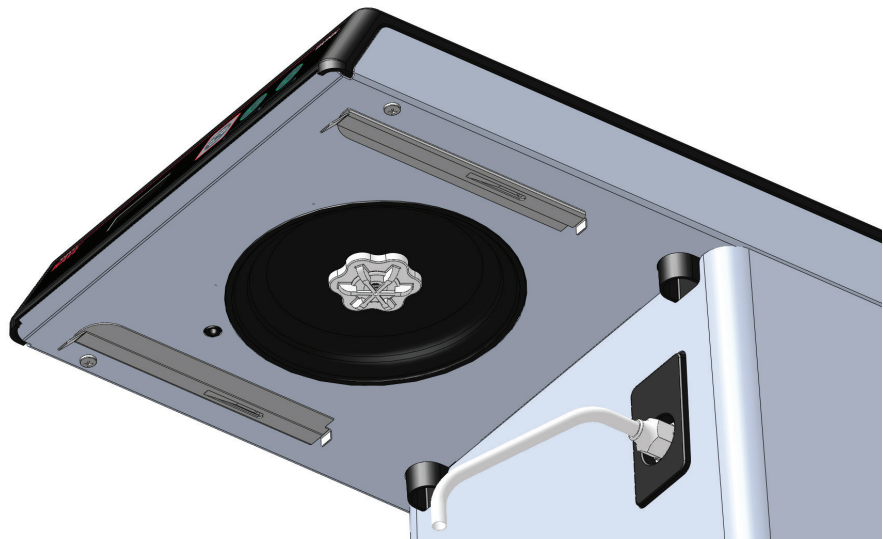

COVER REMOVAL

Unplug the brewer and let it cool down before proceeding.

Front Wrap:

1. Remove the brew funnel.
2. Remove upper and lower screws on either side of front cover.
3. Loosen middle screw on either side of front cover.
4. Pull front cover towards front of brewer.

Top Cover:

1. Remove both screws.
2. Lift top cover to clear front tabs.

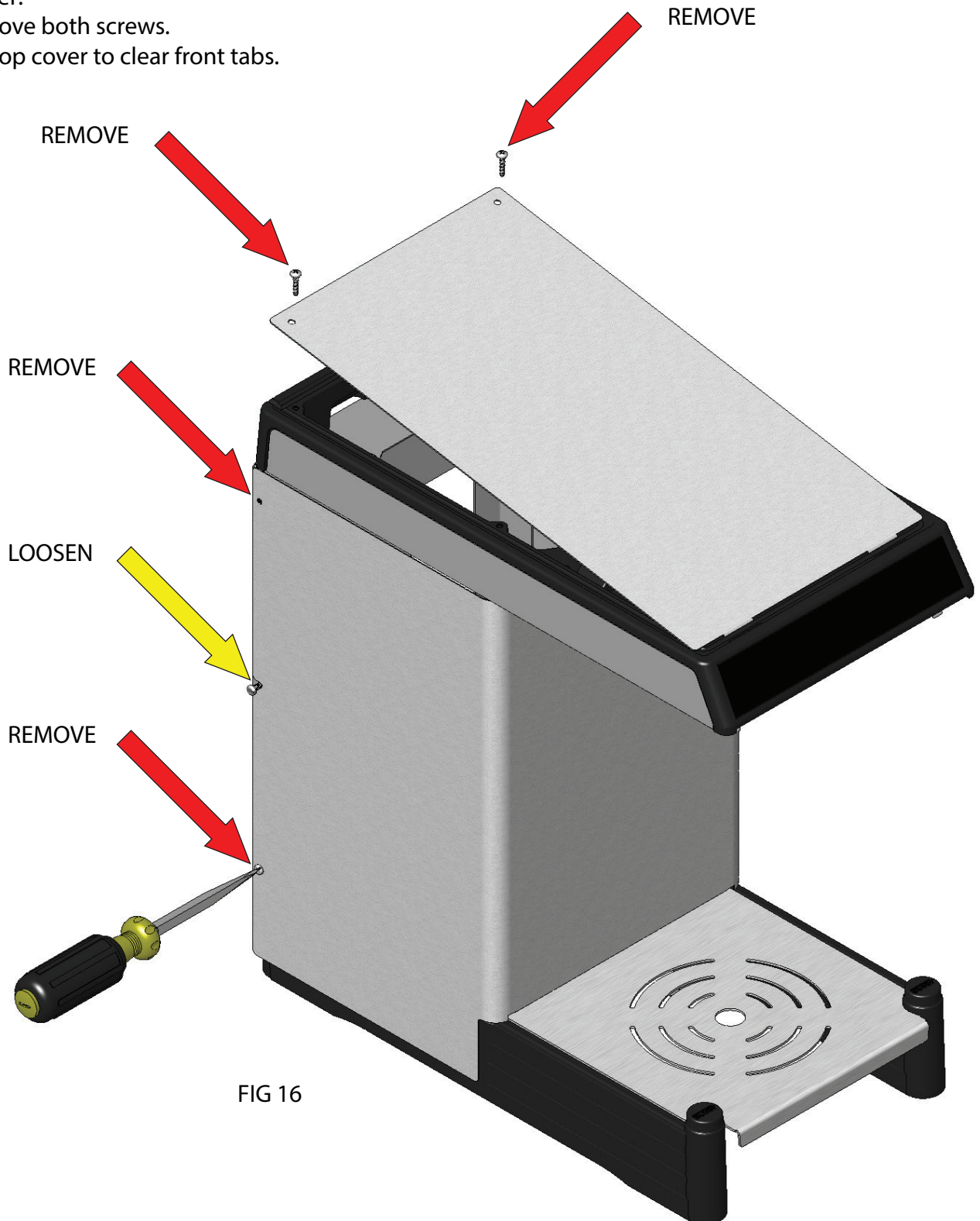
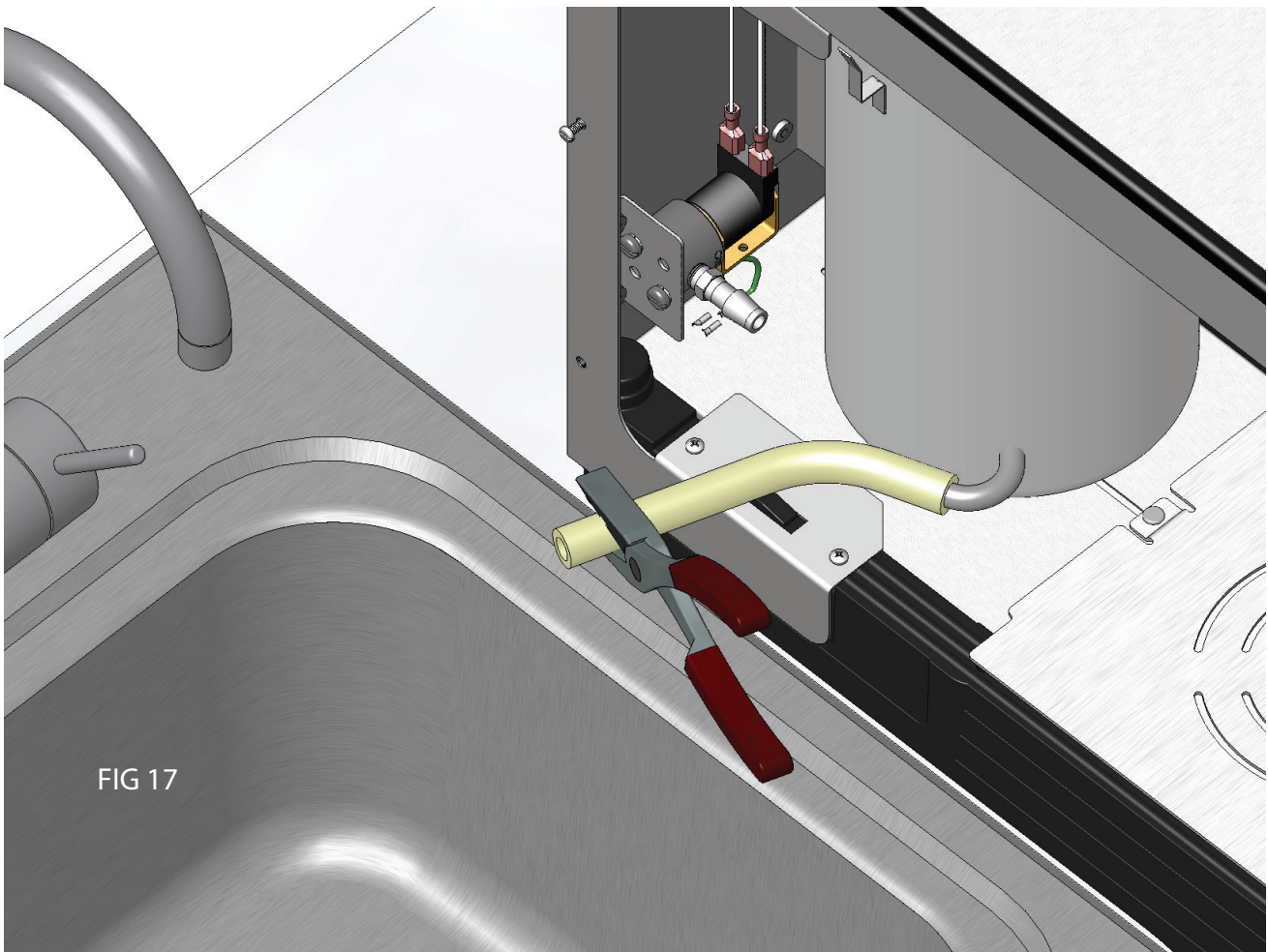

FIG 16

DRAINING TANK

1. Unplug the brewer and let it cool down before proceeding.
2. Remove the brew funnel.
3. Remove the front cover.
4. Pinch fill hose.
5. Loosen clamp from fill solenoid..
6. Remove hose from solenoid and drain into sink as shown (or 2 gallon bucket).
7. After draining, reinstall hose and clamp. (Hand tighten only).



SWITCH SETTINGS

Program Switches:

1. Unplug the brewer and let it cool down before proceeding.
3. Remove the left rear cover.
4. Flip the dip switches as needed.

NOTE: All switches are turned OFF from factory.

KEY #	FUNCTION - OFF	FUNCTION - ON
4. High altitude	Set temp 200°F (93°C)	Set temp 190°F (87.8°C)
3. Energy Save	No energy save mode	Dropsto 140°F (60°C) @ 6 hours / OFF @ 26h
2. Brew lockout	Brew @ any temp	Only brews when it indicates ready
1. Program lockout	Programming allowed	All programming locked out

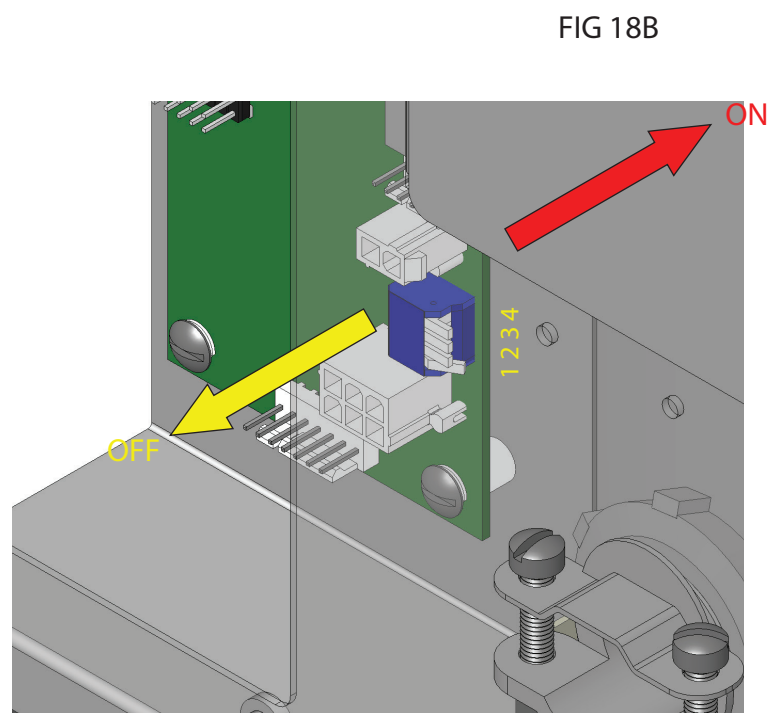
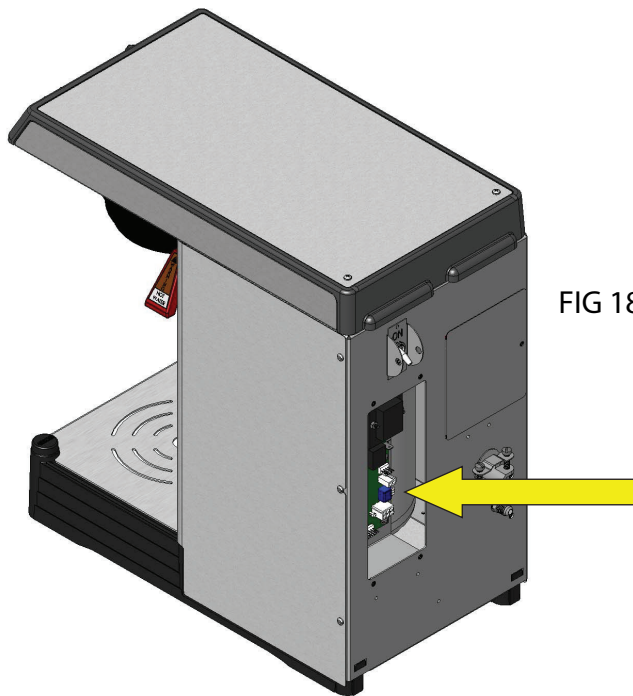

TROUBLESHOOTING

RED LED FLASHES	DISPLAY	DESCRIPTION	ACTION
1.	ER 1	TEMP SENSOR SHORTED	CALL SERVICE
2.	ER 2	TEMP SENSOR OPEN	CALL SERVICE
3.	ER 3	HEATING TOO LONG	CALL SERVICE
4.	ER 4	REFILL TOO LONG	CHECK WATER SUPPLY
5.	ER 5	HIGH TANK LEVEL-DURING BREW	DELIME
6.	ER 6	CHECK "ENABLE BREW ON/OFF" SWITCH	CHECK SWITCH
7.	ER 7	CHECK "BREW A"/"LARGE" SWITCH	CHECK SWITCH
8.	ER 8	CHECK "BREW B"/"LARGE" SWITCH	CHECK SWITCH
Not Applicable	ER 9	CHECK "HIDDEN" SWITCH	CHECK SWITCH

SCHEMATIC WIRING DIAGRAM WAVE 15 APS, 15 S APS

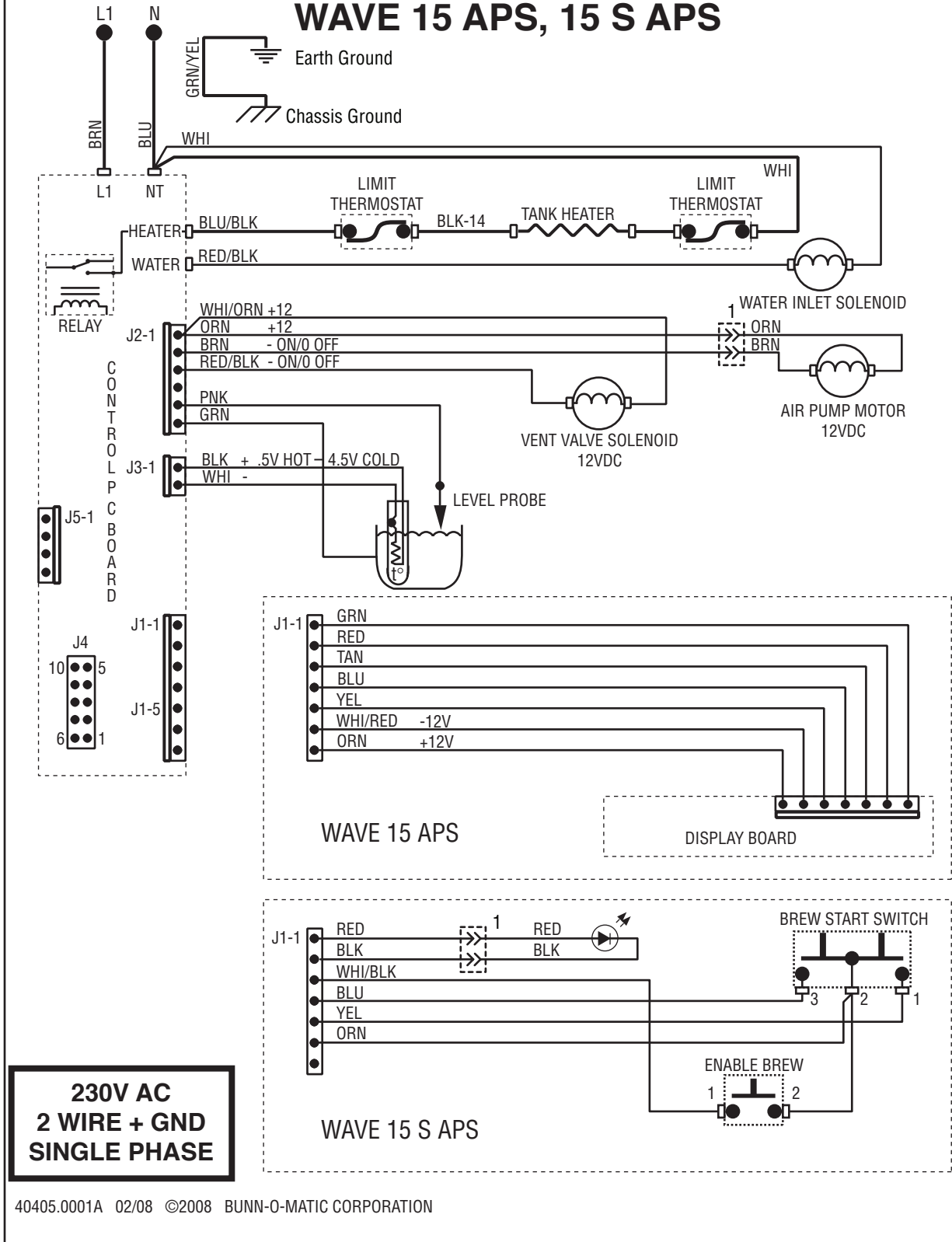

SCHEMATIC WIRING DIAGRAM WAVE 120/240V APS SERIES

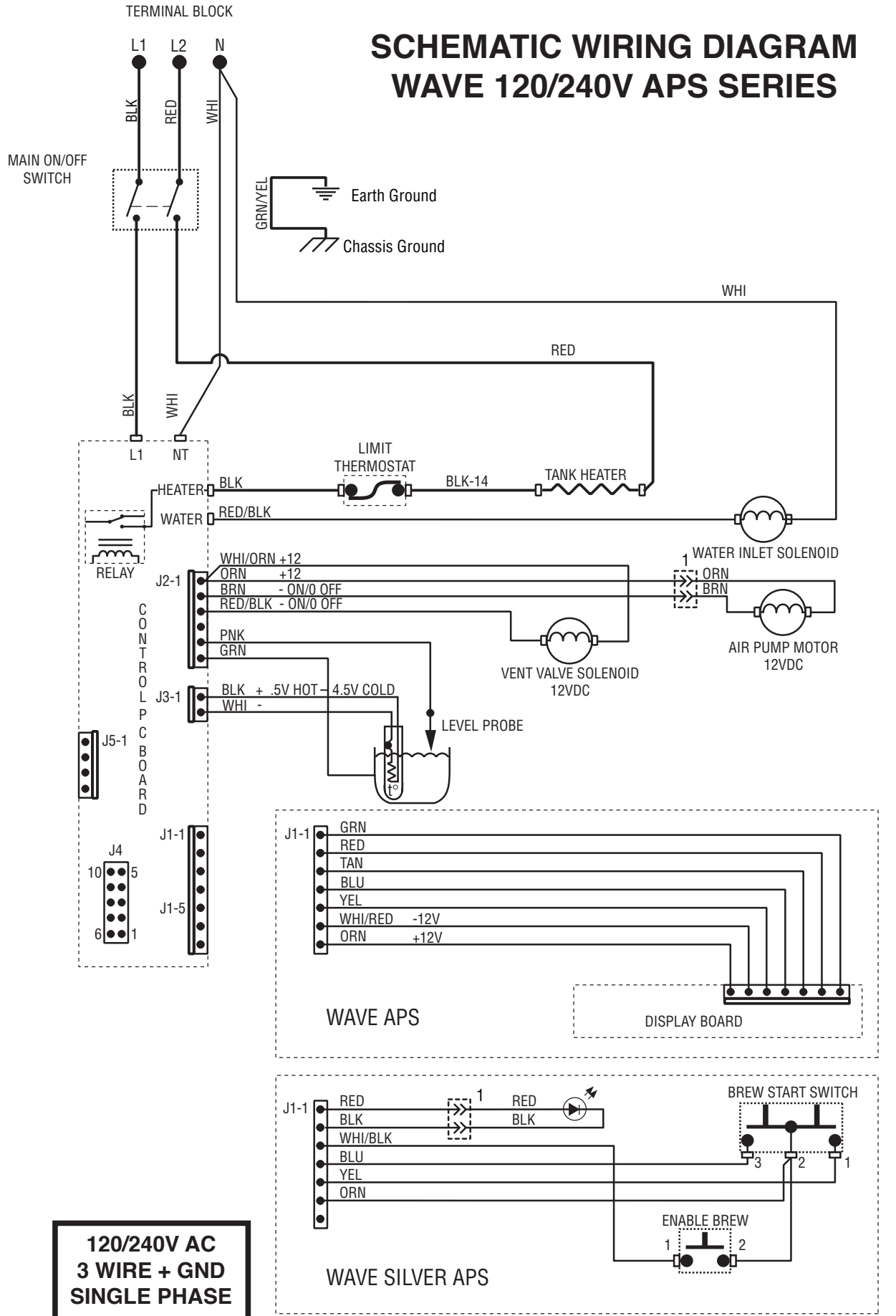

**120/240V AC
3 WIRE + GND
SINGLE PHASE**

SCHEMATIC WIRING DIAGRAM WAVE 15 APS, 15 S APS

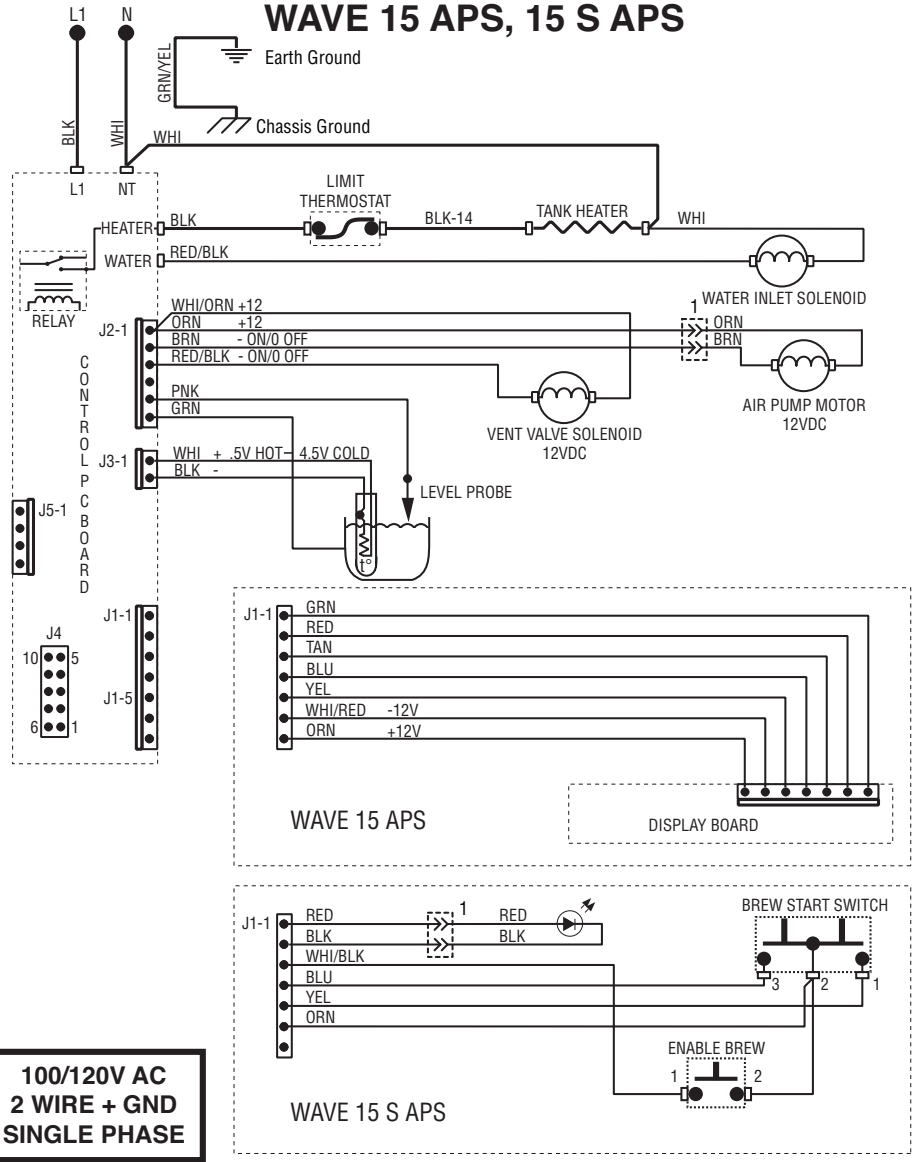

40405.0003A 04/10 ©2010 BUNN-O-MATIC CORPORATION

SCHEMATIC WIRING DIAGRAM WAVE 15 COFFEE TEA COMBO

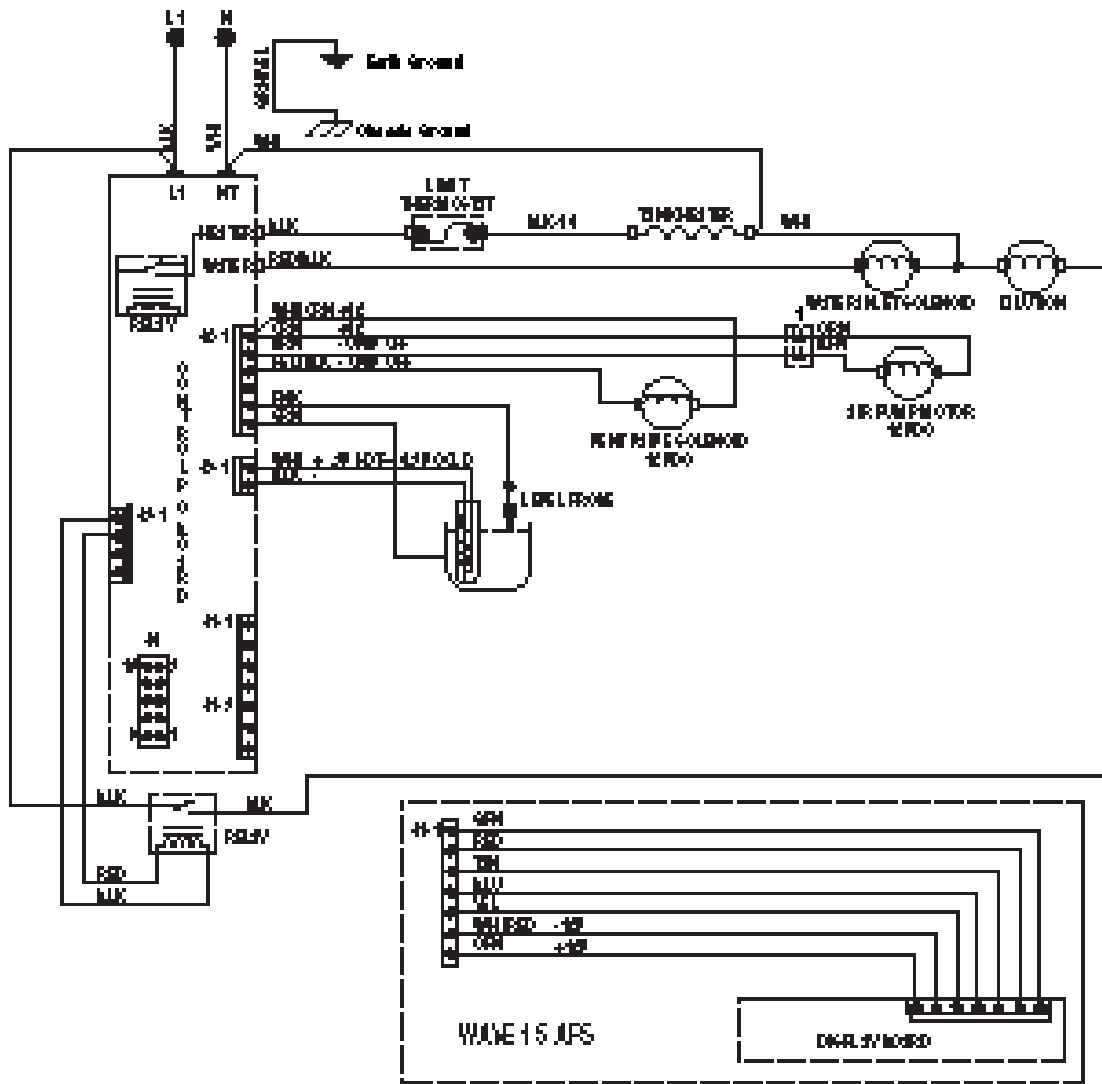

100H20V AC
 2 WIRE + GND
 SINGLE PHASE

WAVE 15 APS IS A TRADE MARK OF WAVE ELECTRONICS